

TA71 Evaporator

Industry
exclusive 2
year, unlimited
mileage, limited
warranty

**A rear or front
mounted freeblow
evaporator that
can be used as
a tie-in with
OEM components
or as part of a
complete
Trans/Air system**

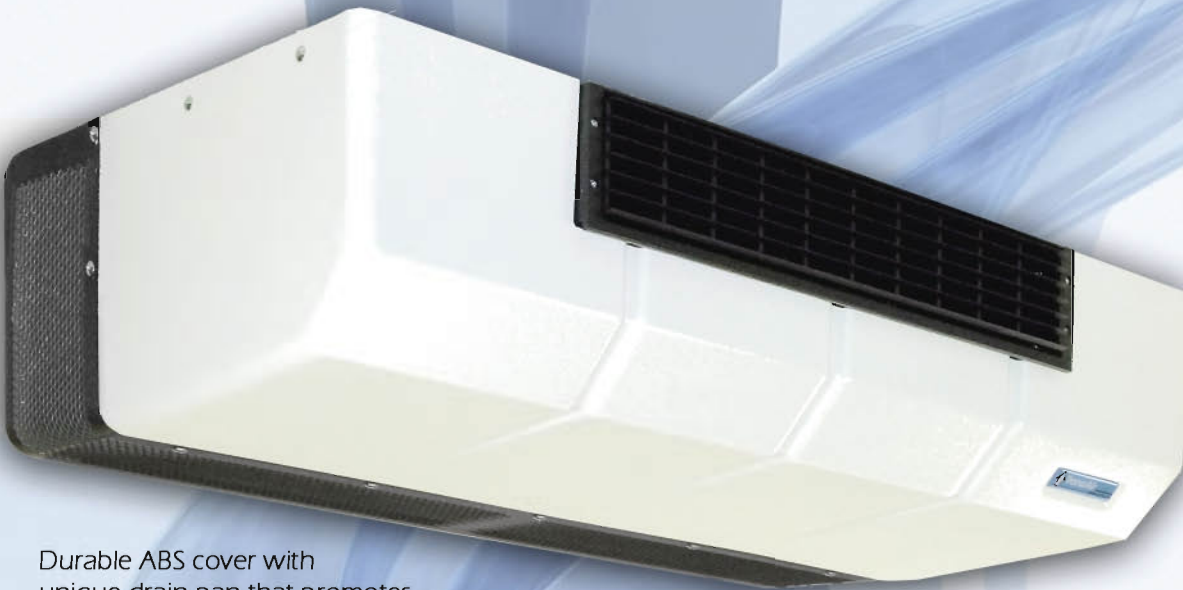

Durable ABS cover with
unique drain pan that promotes
proper condensate removal
(available in white, gray, and spring white)



Enhanced tube & fin design
provides highest capacity



Heavy Duty galvanized
steel enclosure for reduced
air leakage and maximum
durability

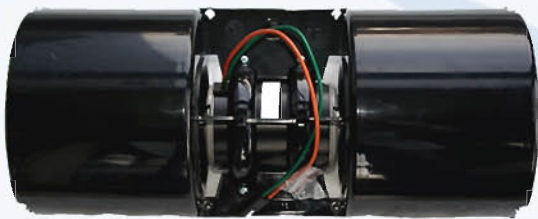

Blower assemblies come equipped
with larger blower wheels for maximum
air flow and motors utilize custom
wound armatures for lower current
draw and greater efficiency



4 Ton externally equalized, thermostatic expansion
valve that precisely controls refrigerant and prevents liquid
slugging to the compressor or starved evaporator



School & Commercial Bus Climate Control Design | Manufacture | Install | Service

Trans/Air Manufacturing Corporation is an ISO 9001 registered firm committed to providing
world class climate control products and services to the bus and commercial vehicle markets.



TA71 Evaporator

General

- Freeblow air distribution
- Weight lb (kg): 46 (21)
- Box Size in (mm): 45 x 22 x 14 (1140 x 560 x 360)
- Cube ft³ (m³): 8 (.23)

Cooling Capacity

- BTU/hr: 25,031 (SAE) to 45,000 (IMACA) *

Heating Capacity

- BTU/hr: 28,489 (Actual capacity varies based on engine operating temperature and hot water flow rate)

Cover

- ABS cover
- Seperate drain pan with sump
- (1) Multi-directional louvers
- Washable / reusable filter
- (2) 5/8 in ID drain hoses

Blower Assemblies

- (2) 4.5 in diameter blower wheels
- Amperage draw: 9.2 Amps @ 13.5 Vdc (4.6 Amps @ 27 Vdc)
- Total air flow 740 ft³/min (1257 m³/hr) @ 0 static
- (1) Double shafted, single speed, permanent magnet motors

Evaporator Coil

- (1) Coil
- Face area in² (cm²): 204 (1316)
- 3/8 in enhanced copper tubing
- Fins: 0.006 in raised lance, 10 FPI
- (3) Row

Electrical

- Color coded in fire retardant loom
- Low and high pressure swtiches

Expansion Valve

- (1) 4 Ton externally equalized thermostatic type

Available Options

- Metal cover for use with with OEM installation
- Heat coil used with positive isolator valve. Isolator valve and heater hose not included.
- Coil corrosion protection

Warranty

- 2 year unlimited mileage limited warranty within the continental U.S. and Canada. Terms of Trans/Air's domestic and export warranty policies are available upon request.

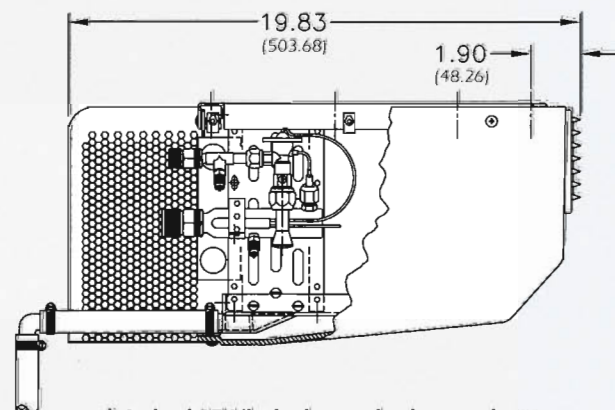
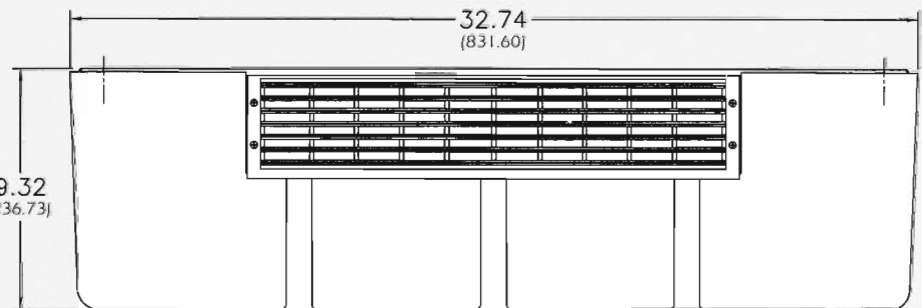
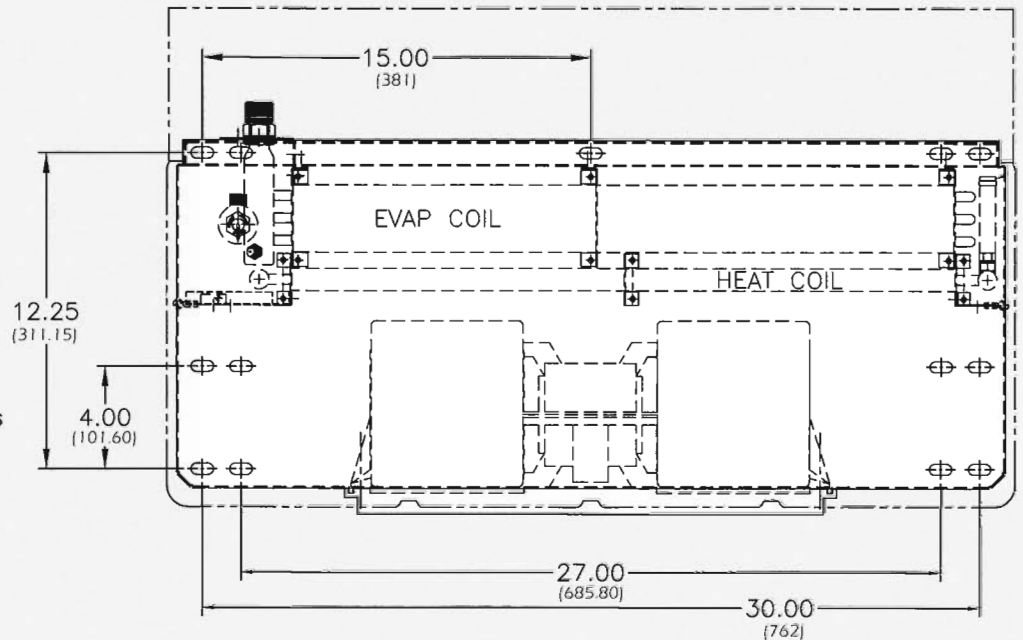

* Actual BTU/hr is dependant on system combination and rating conditions used

- Specifications subject to change without notice
- All measurements in standard (metric)
- Contact Trans/Air for more information