

TA73 Evaporator

Industry
exclusive 2
year, unlimited
mileage, limited
warranty



A rear or front mounted freeblow evaporator that can be used as a tie-in with OEM components or as part of a complete Trans/Air system

Durable ABS cover with unique drain pan that promotes proper condensate removal (available in white, gray, and spring white)



Enhanced tube & fin design provides highest capacity



Heavy Duty galvanized steel enclosure for reduced air leakage and maximum durability

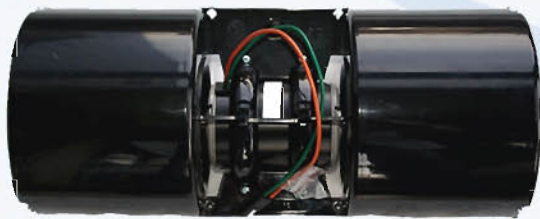

Blower assemblies come equipped with larger blower wheels for maximum air flow and motors utilize custom wound armatures for lower current draw and greater efficiency

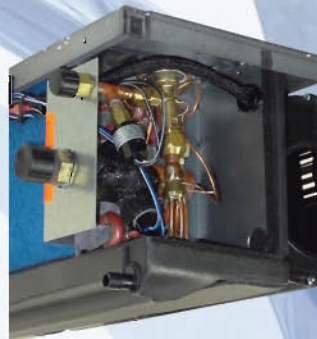

4 Ton externally equalized, thermostatic expansion valve that precisely controls refrigerant and prevents liquid slugging to the compressor or starved evaporator



School & Commercial Bus Climate Control Design | Manufacture | Install | Service

Trans/Air Manufacturing Corporation is an ISO 9001 registered firm committed to providing world class climate control products and services to the bus and commercial vehicle markets.



FM 39947

TA73 Evaporator

General

- Freeblow air distribution
- Weight lb (kg): 52.8 (24)
- Box Size in (mm): 45 x 22 x 14 (1140 x 560 x 360)
- Cube ft³ (m³): 8 (.23)

Cooling Capacity

- BTU/hr: 41,000 (SAE) to 65,000 (IMACA) *

Heating Capacity

- BTU/hr: 40,000 (Actual capacity varies based on engine operating temperature and hot water flow rate)

Cover

- ABS cover
- Separate drain pan with sump
- (2) Multi-directional louvers
- Washable / reusable filter
- (2) 5/8 in ID drain hoses

Blower Assemblies

- (4) 4.5 in diameter blower wheels
- Amperage draw: 16.9 Amps @ 13.5 Vdc (8.5 Amps @ 27 Vdc)
- Total air flow 1480 ft³/min (2515 m³/hr) @ 0 static
- (2) Double shafted, single speed, permanent magnet motors

Evaporator Coil

- (1) Coil
- Face area in² (cm²): 280 (1806)
- 3/8 in enhanced copper tubing
- Fins: 0.006 in raised lance, 10 FPI
- (3) Row

Electrical

- Color coded in fire retardant loom
- Low and high pressure switches

Expansion Valve

- (1) 4 Ton externally equalized thermostatic type

Available Options

- Metal cover for use with OEM installation
- Heat coil used with positive isolator valve. Isolator valve and heater hose not included.
- Coil corrosion protection

Warranty

- 2 year unlimited mileage limited warranty within the continental U.S. and Canada. Terms of Trans/Air's domestic and export warranty policies are available upon request.

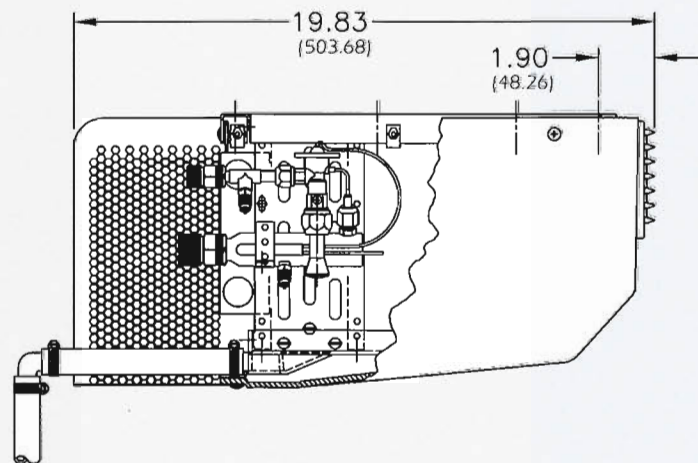
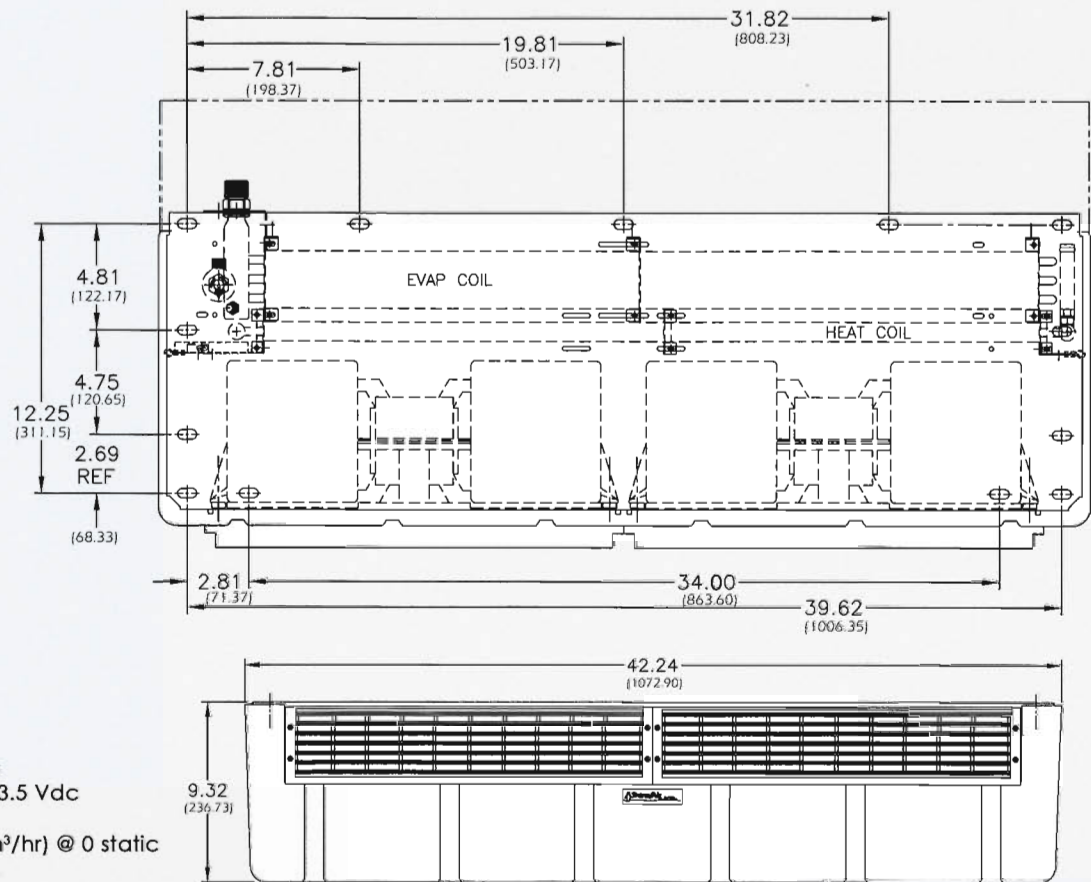

* Actual BTU/hr is dependant on system combination and rating conditions used

- Specifications subject to change without notice
- All measurements in standard (metric)
- Contact Trans/Air for more information