



## **Air Conditioning System**

## **Operation Manual**

### **CC145 Compact Cooler**

4/2013  
P.N. 10000034A

To receive the best performance from the air conditioning system, we suggest carefully reading this manual before operating the unit. Keep this manual in the vehicle for future reference.

## Table of Contents

		Page
	INTRODUCTION.....	2
	SAFETY PRECAUTIONS.....	3
	SPECIFIC WARNINGS.....	4
1 -	EQUIPMENT GENERAL ARRANGEMENT.....	6
1.1 -	CC145 AIR CONDITIONER COMPONENTS.....	6
2 -	CONTROLS AND INDICATORS.....	7
2.1 -	FUNCTION OF THE MANUAL CONTROL PANEL.....	7
2.2 -	MANUAL CONTROL AC REGULATION.....	8
2.3 -	FUNCTION OF THE ELECTRONIC CONTROL PANEL.....	9
2.4 -	FUNCTION OF THE ELECTRONIC CONTROL AND INDICATOR.....	10
3 -	EQUIPMENT OPERATION.....	11
3.1 -	COMMAND DESCRIPTION – NORMAL OPERATION.....	11
3.2 -	COMMAND DESCRIPTION – FAILURE MODE.....	12
3.3 -	ELECTRICAL MALFUNCTIONS.....	13
3.4 -	AIR CONDITIONING SYSTEM MALFUNCTIONS.....	13
4 -	PREVENTIVE MAINTENANCE ACTIVITIES.....	15
4.1 -	GENERAL.....	15
4.2 -	PREVENTIVE MAINTENANCE SCHEDULE.....	16
5 -	TECHNICAL SPECIFICATIONS.....	17
6 -	FAILURE DIAGNOSIS TABLE.....	18
7 -	ELECTRICAL SCHEMATICS OF RELAY BOARD AND CONTROL PANEL.....	20
7.1 -	RELAY AND FUSE LOCATION.....	20
7.2 -	RELAY BOARD SCHEMATIC.....	21
8 -	ELECTRIC SCHEMATIC OF DIGITAL CONTROL PANEL AND RELAY BOARD.....	22
8.1 -	DIGITAL CONTROL PANEL.....	22
8.2 -	RELAY BOARD LAYOUT (12V).....	23
8.3 -	WIRING SCHEMATIC.....	24
8.4 -	WIRING SCHEMATIC WITH NOISE SUPPRESSION RELAY.....	25

## INTRODUCTION

At Spheros, we develop our products with the goal of providing a comfortable environment for vehicle passengers. We are always looking for the best air condition concepts that provide the highest performance at the best possible value.

The compact systems are simple to operate and provide high cooling capacities at low noise levels.

This manual was developed with the purpose of presenting critical functional aspects, describing the ease of operation and recommended maintenance necessary to obtain the best performance from the Spheros Air Conditioning system.

To ensure a long, useful and problem free life from the equipment it is essential that the operation and maintenance instructions described in this manual are followed routinely and thoroughly.

All system controls provided by Spheros, are duly illustrated and explained in this manual.

It is important that the operator reads and understands the operation instructions carefully before starting the air conditioning equipment.

Spheros makes every effort to maintain a network of authorized service professionals trained to perform any type of maintenance within the quality standard.

Thank you for choosing Spheros Air Conditioning products. If you have any questions or concerns with our products, please contact us or the nearest authorized service provider.

**Spheros Climate Systems, LLC**  
**5536 Research Drive**  
**Canton, MI 48188**

**Phone 1-734-218-7350 Toll free 1-888-960-4849**

---

## SAFETY PRECAUTIONS

### GENERAL SAFETY NOTICES

The following safety notices supplement warnings and cautions appearing elsewhere in this manual. The following are recommended precautions that must be understood and applied during operation and maintenance of the equipment. **Failure to adhere to warnings and cautions may result in damage to equipment, fire, personal injury and even death.**

### OPERATING PRECAUTIONS

Keep hands, clothing and tools clear of the evaporator and condenser fans.

No work should be performed on the system unless battery power is disconnected.

In case of severe vibration or unusual noise, stop the system and investigate.

### MAINTENANCE PRECAUTIONS

Always wear protective eye wear (safety glasses or goggles) and appropriate safety wear.

Never perform any maintenance or service on your equipment before consulting with authorized service personnel. Always unplug unit before attempting any maintenance.

Avoid breathing any refrigerant vapor, lubricant vapor, or mist. Exposure to these, particularly PAG oil mist may irritate your eyes, nose, or throat.

Never use compressed air (shop-air) to leak-test or pressure test a R134A system. Under certain conditions, pressurized mixtures of R134A and air can be combustible. In addition, shop air will inject moisture into the system.

Always use mineral oil to lubricate "O" Rings, hoses, and fittings on R134A systems. PAG oils absorb moisture and become very acidic and corrosive. Mineral oil does not absorb moisture and thus prevents corrosion. Always wear gloves when working with PAG (Polyalkylene Glycol) and Ester (POE or Polyester) lubricants to prevent irritation to your skin. R134A lubricants can damage vehicles paint, plastic parts, engine drive belts and coolant hoses.

Beware of unannounced starting of the evaporator and condenser fans. Do not remove the evaporator/condenser cover without disconnecting the vehicle battery cable. Be sure power is turned off before working on motors, controllers, and electrical control switches. Tag system controls and vehicle battery to prevent accidental energizing of the system.

In case of electrical fire, extinguish with CO<sub>2</sub> (never use water). Disconnect vehicle battery power if possible.

---

## SPECIFIC WARNINGS AND CAUTIONS

### WARNING

Be aware of unannounced starting of the evaporator and condenser fans. The unit may cycle the fans and compressor unexpectedly as control requirements dictate.

### WARNING

The refrigerant contained in the air conditioning system when in direct contact with skin and eyes can cause frostbite, severe burns or blindness.

### WARNING

Be sure to observe warning listed in the safety precautions in the front of this manual before performing maintenance on the air conditioning system.

### WARNING

Never use air for leak testing. Pressurized, air-rich mixtures of refrigerants and air are combustible when exposed to ignition source.

## SPECIFIC WARNINGS AND CAUTIONS

### WARNING

Do not use a nitrogen cylinder without a pressure regulator. Do not use oxygen in or near a refrigeration system as an explosion may occur.

### WARNING

The filter-drier may contain liquid refrigerant. Slowly open the fitting nuts and avoid contact with exposed skin or eyes.

### CAUTION

Unless there was a catastrophic failure, such as a blown or ruptured refrigerant hose, additional oil may not be needed.

### CAUTION

Use only the exact oil specified by the compressor manufacturer. Use of oil other than that specified will void the compressor warranty.

## 1. Equipment General Arrangement

### 1.1 CC145 Air Conditioner Components

The CC145 air conditioner and its main components are shown in **Fig. 1**.

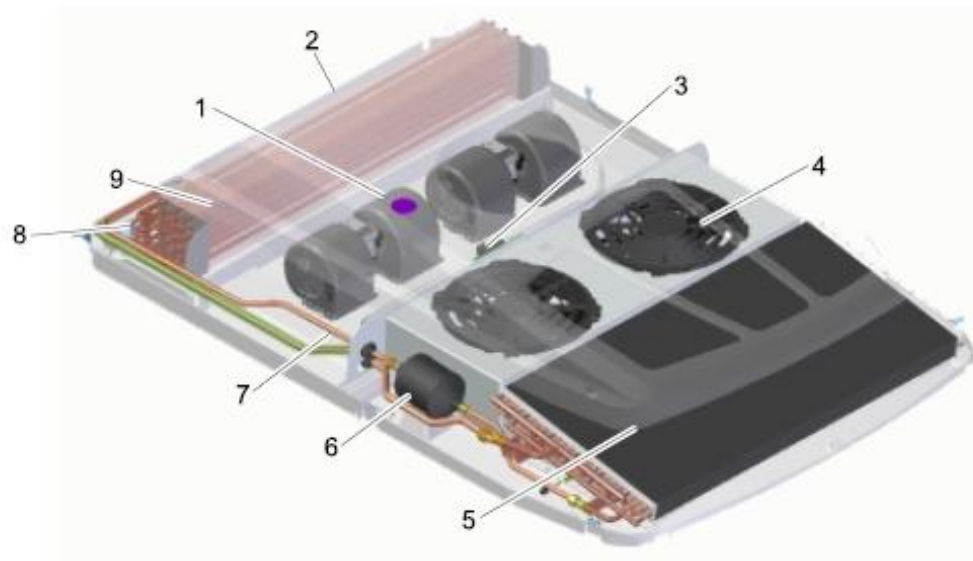

1. Evaporator Blower
2. Internal Sensor
3. Relay Board (12V/24V)
4. Condenser Fan
5. Condenser Coil
6. Receiver / Filter Drier / Sight Glass
7. Solenoid Valve
8. Expansion Valve
9. Evaporator Coil

**Fig. 1**

## 2. Controls and Indicators

### 2.1 Functions of the Manual Control Panel

The air conditioner control panel has two rotary switches, one for the blower speed (E) and one for the temperature adjustment (G). It also has an LED indicator (F) to signal activation of the AC compressor drive clutch. **Figure 2** shows the features of the control panel.



**Fig. 2: Manual Control Panel**

- A: A/C System OFF
- B: Blower Switch, Low Mode
- C: Blower Switch, Medium Mode
- D: Blower Switch, High Mode
- E: Blower Switch
- F: Compressor Operation LED
- G: Temperature Adjust Switch

#### Temperature Adjustment Switch

The Temperature Adjust Switch (G) is used to set the ideal or desired temperature level for the user. This can be varied between approximately 64°F (18°C) and 78°F (26°C). The system is then automatically regulated and operates until the set value is obtained.

#### Cooling Compressor LED

The LED indicator (F) lights blue while the AC Compressor Clutch is activated, the condenser fans are running and the cooling system is active. The LED turns off when the cabin temperature falls to the set level.

#### The Blower Switch

The blower motors have three modes of operation controlled by the Blower Switch (E) – Low, Medium and High speed. The blowers do not run and no cooling occurs at the OFF position (A).

The Low (B) Medium (C) and High (D) switch positions keep the blowers continuously running at low, medium or high fixed speeds respectively, independent of the set or actual temperature values.



## 2.2 Manual Control AC Regulation

### AC Regulation

The A/C regulation is based on the difference between the actual cabin temperature and the set value. This is illustrated in **Figure 3**

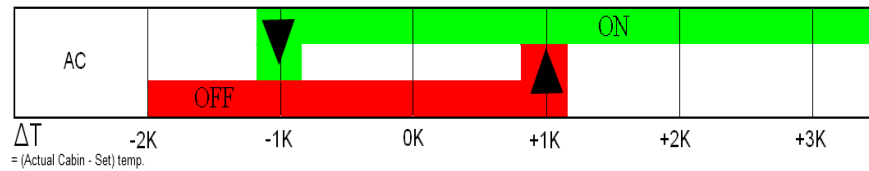
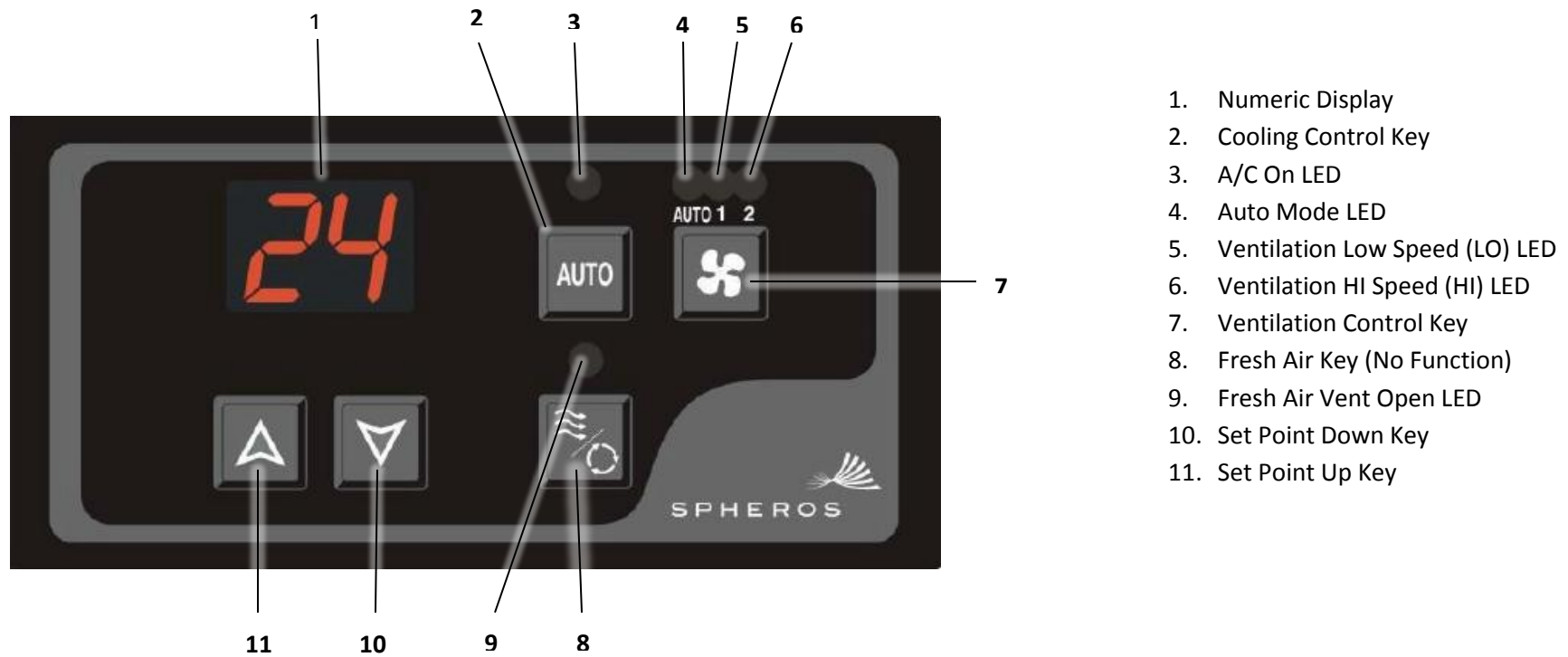

**Fig. 3: AC Regulation**

Cooling (activated A/C Compressor Clutch and Condenser Fans) starts only after the temperature difference exceeds 1.8°F/1°C and stops when the cabin temperature difference is 1.8°F/1°C less than the set value.

### 2.3 Functions of the Digital Control Panel

The air conditioner control panel has a main CPU and a keyboard to control the operation of the system and provides visual display of operation status. The control panel and its controls and indicators are shown in **Fig. 4**.



**Fig. 4: Digital Control Panel**

## 2.4 Function of Digital Control and Indicators

The function of the controls and indicators is shown in **Fig. 5**.

**Note:**

All keys have backlit red LED's,

Index Fig. 2	Control / Indicator	Setting / Indication	Function
1	Display	°F	Ignition on, system in standby for activation by pressing Auto Key. Ventilation only is possible by pressing Ventilation Key.
		Number or Code	System in operation. Indication of temperatures, ventilation speed, failure codes and status information depending on system operational mode and indication selections. For details refer to "Command Description".
2	Auto Mode ON/OFF Key	Pressed	The controller will automatically chose one of the available functions (cooling or heating).
3	Auto Mode ON LED	Lit	A/C mode is on, system operates in air conditioning or heating mode.
4	AUTO Ventilation Mode LED	Lit	AUTO Fan Speed Mode is on, fan operates in AUTO Mode.
5	LOW Speed Ventilation LED	Lit	Indication of Low Speed Ventilation manually selected with ventilation key. AUTO mode LED is off.
6	HI Speed Ventilation LED	Lit	Indication of HI Speed Ventilation manually selected with ventilation key. AUTO mode LED is off.
7	Ventilation Control Key	Pressed	Ventilation Mode provides two operation speeds of the fan.
8	Fresh Air Key	Pressed	Allows external air to enter the vehicle and can be automatic depending upon internal temperature.
9	Fresh Air Vent Open Led	Lit	Indication of Fresh Air Vent Open and Off when vent is closed.
10	Set Point Down Key	Pressed	Lowers Temperature Set Point and operating parameters
11	Set Point Up Key	Pressed	Raises Temperature Set Point and operating parameters

**Fig. 5 Function of Controls and Indicators**



### 3. Equipment Operation

#### 3.1 Command Description – Normal Operation

##### Display

The two digit numeric display  is used for informing the operator about the selected set temperature.

##### Set-Point

The set-point is the desired temperature inside the vehicle. The actual selected set point temperature blinks and may be adjusted by pressing the  or  keys.

##### Automatic Mode



1 - To select the Automatic Mode press the  key.

In the Automatic Mode the controller will automatically chose one of the available functions (cooling or heating), according to the set point temperature.

2 – To disable the Automatic Mode, press the  key again.

##### Ventilation Mode

The Ventilation function is activated by pressing the  key.

There are two operation speeds. Press the  key once to select the **LO** ventilation speed, press the  key a second time to select **HI** ventilation speed.

##### Cooling Mode

After selecting the Automatic Mode and the internal temperature of the vehicle is above the desired set point, the system will start operating in the cooling mode and selects the evaporator blower speed automatically.

When the system starts up in the cooling mode the evaporator's blowers will start in the automatic mode according to the set point programming. Ventilation speeds may be changed manually with the  key.

## 3.2 Command Description – Failure Operation

### Failure Operation – Control Panel Functions

The system indicates failure codes on the display. The possible failure codes and their meanings are shown in **Fig. 6**.

Failure	Possible Cause	Check and Correct
HA	Pressure switch failure Anti-Icing Thermostat Failure	Check pressure switch Check anti-icing thermostat Check evaporator Check refrigerant pressure Check evaporator blowers
OP	Temperature Sensor Open	Check condition of temperature sensor Check temperature sensor wiring
SC	Temperature Sensor Short Circuit	Check condition of temperature sensor Check temperature sensor wiring
AL	Electrical Power Failure	Check battery voltage Check wiring Check alternator

**Fig. 6 Failure Code Indications**

1 – If any failure occurs to the pressure switch, the display will show the message **(HA)** and the system will shut the compressor off. The Controller has a 30 minute delay before allowing the compressor and condenser fans to restart.

2 – As the system operates according to the internal temperature, the controller has two failure codes to monitor the temperature Sensors:

- a) If the temperature sensor is open, the display will show **(OP)**.
- b) If the temperature sensor is shorted, the display will show **(SC)**.

3 – The controller has a parameter to monitoring the alternator. If a failure occurs the display will show **(AL)**.

### 3.3 Electrical Malfunctions

The individual circuits are to be checked systematically in accordance with the wiring diagram. The plug connections and electrical components such as switches, relay, etc. should be checked.

The following are possible causes of electrical malfunctions and should always be checked first so they can be excluded as the cause of the failure:

- Corroded plug contacts
- Loose plug contacts
- Corroded wires
- Corroded battery terminals
- Broken wires
- Defective fuses

### 3.4 Air Conditioning System Malfunctions

The following failures may occur in the air conditioning system and may lead to a fault lockout of the system:

- Activated freeze protection sensor
- Activated high / low pressure switch
- Defective compressor
- Defective evaporator or condenser fans
- Refrigerant loss due to leaks
- Plugged air filter or dirty heat exchanger fins
- Restricted refrigeration circuit (filter drier)
- Defective expansion valve

### 3.5 Malfunctions in the Refrigeration Circuit

If malfunctions occur in the refrigeration circuit of the air conditioning system, the system must be checked and properly repaired by an authorized air conditioning service professional.

#### **CAUTION**

**The refrigerant is not allowed to be released to the atmosphere. Regulatory requirements mandate that individuals who open a system or container containing a controlled refrigerant be certified.**

Check the refrigerant charge in the system:

- After the air conditioning system has been operating for approx. 5 min. with the electromagnetic clutch activated and the engine running at a rapid idle, the refrigerant should flow through the sight glass without forming any bubbles.

During the cold season:

- To prevent the shaft seal of the compressor from drying out and leaking, operate the air conditioning system for approx. 15 min. twice a month at ambient temperatures above 46°F (8°C).

The refrigerant receiver as well as all components of the air conditioning system should be visually inspected during the maintenance activities. Special attention should be directed to any signs of corrosion and mechanical damage.

All components that are not in perfect condition must be replaced for safety reasons.

### **CAUTION**

**The pressure vessels directive requires the operator to have the refrigerant receiver checked by an authorized service professional at regular intervals.**

### **Note**

To ensure trouble free operation of the air conditioner, the refrigeration oil and filter drier must be replaced 6 months after the initial operation of the vehicle or if there is a change in color of oil.

- a) Yellow – Normal oil
- b) Black – Carbonized oil
- c) Brown – Copper Corrosion, due to moisture in system
- d) Metallic Gray – Suspended metallic particles

The filter drier should be replaced every year at the beginning of the season or every time system is exposed to contamination. These activities must be performed by an authorized service company which should also perform a functional check of the air conditioner as well as a leak test of the system.

Warranty claims can only be accepted if the claimant can prove that the maintenance and safety instructions have been strictly observed.

## 4. Preventative Maintenance Activities

### 4.1 General

An air-conditioning system just as all other parts of the vehicle subjected to constant mechanical strain and stress. To ensure trouble-free operation of the system and to avoid any damage to its parts, it is important that all required service activities on the air conditioning system are performed by trained and qualified personnel who are knowledgeable in the field of refrigeration.

The proper handling of the system including proof of the service activities record is a prerequisite for acceptance of any warranty claims in the event of damage to parts subject to maintenance.

Warranty replacement parts and out of warranty replacement parts must be supplied by Spheros Climate System, LLC to assure the quality and reliability of the product.

Regardless of the maintenance intervals specified in the maintenance and service schedule, all attachments of the unit and the connections of the refrigerant lines must be checked for tightness within the first four weeks following the initial start-up of the air-conditioning system or the vehicle.

Even if the air-conditioning system is not in operation, wear caused by normal aging or the strain and stress occurring during the driving operation of the bus may occur on individual components. All checks listed in the maintenance and service schedule need to be independent of the operation hours of the system.

Loss of refrigerant is possible even if the refrigerant connections are tight due to the structure of the material of the refrigerant lines and the ambient temperatures. In the event of a relatively high refrigerant loss within short intervals, leaks in the system can be assumed.

During long periods of non-use, the air-conditioning system should be operated for about 15 minutes at least twice a month in order to prevent the shaft seals of the compressor from hardening.

The drive pulley of the electromagnetic clutch is continuously rotating when the vehicle engine is in operation. Bearing wear or possible damage to the clutch may occur and should be inspected independently of maintenance intervals based on the operating time of the air-conditioning system. It is imperative that the clutch be checked for correct lubrication, belt tension etc.

### CAUTION

- The refrigerant receiver is subject to the Pressure Equipment Directive. Check the receiver every 6 months for cracks, mechanical damage or corrosion. The receiver must be replaced if any defects are found.
- The maintenance intervals indicated in the maintenance and service schedule are based on the operation hours of the vehicle, with the exception of the compressor assembly, which are based on the air-conditioning unit's hours of operation.
- These time intervals are empirical values that may vary widely depending on the type of system and type of bus concerned.



## 4.2 Preventive Maintenance Schedule

All preventive maintenance described below is based on typical operating conditions. The frequency outlined below is for normal operating conditions and should increase if used under more severe conditions.

<b>COOLING CIRCUIT</b>	<b>MONTHLY</b>	<b>QUARTERLY</b>	<b>ANNUALLY</b>
Measure and record the refrigerant pressures and temperatures of the suction line		X	
Measure and record the refrigerant pressures and temperatures of the liquid line		X	
Visually inspect for signs of oil or refrigerant leaks	X		
After 15 minutes of operation check refrigerant level using the sight glass	X		
Visually inspect all components, tubes and hoses for signs of wear and deterioration	X		
Change the filter drier once a year or each time the system is opened			X
Check the opening and closing pressures of the high and low pressure switches			X

<b>COMPRESSOR / CLUTCH</b>	<b>MONTHLY</b>	<b>QUARTERLY</b>	<b>ANNUALLY</b>
Visually inspect the clutch plate		X	
Visually inspect the condition, tension and alignment of the compressor belts	X		
Clean the compressor and clutch with steam or hot water			X
Measure the resistance and the voltage on the clutch coil			X
Check the compressor oil level after 15 minutes of operation	X		

<b>STRUCTURE</b>	<b>MONTHLY</b>	<b>QUARTERLY</b>	<b>ANNUALLY</b>
Visually inspect for loose parts, damaged or broken wires	X		
Clean or replace the return air filters	X		
Clean the condenser and evaporator drains			X
Clean the fins the evaporator and condenser coils with coil cleaner or soap and water	X		
Retighten all bolts on the compressor support and the unit using recommended torque			

<b>ELECTRICAL SYSTEM</b>	<b>MONTHLY</b>	<b>QUARTERLY</b>	<b>ANNUALLY</b>
Check control panel operation, clean panel and thermostat sensor with air			X
Check the alternator for corrosion and inspect electrical connections			X
Visually check the alternator belt tension, check for mis-alignment and wear			X
Check the power cable at the relay plate, re-torque if necessary	X		
Inspect all wires and terminals for damage and corrosion			X
Check the ventilation of the condenser and evaporator motors	X		

**Note:** We recommend using this table to develop a plan for routine maintenance to you A/C System

**IMPORTANT:** The return air filter and the condenser coil must be checked and cleaned weekly. As a rule, the air ducts must be cleaned every 3 months and more frequently depending on operating times of the system, the number of passengers and the severity of the environmental conditions.

**A cost effective preventive maintenance program can prevent costly down time and repairs and avoid cancellation of warranty due to negligence.**

### 5. Technical Specifications

The main specifications for the air conditioning system are shown in **Fig. 7**.

<b>CC145</b>	
Max. Cooling Capacity (BTU/H) / (KW)	42,000 / 12
Dimensions: Length x Width x Height (in) / (mm)	68.5 x 47 x 7.8 / 1740 x 1200 x 200
Weight (lbs) / (kg)	148 / 67
Evaporator Air Flow (CFM) / (m <sup>3</sup> /h)	1,200 / 2040
Supply Voltage (VDC)	12 / 24
Electrical Power Consumption at 12 VDC / 24 VDC (AMPS)	90 / 45
Refrigerant Type	R134A
Number of Evaporator Blowers	2
Number of Condenser Fans	2

\*Evaporator air in 104°F / 40°C, 46% RH, Ambient 95°F / 35°C.

**Fig. 7 Technical Data**

## 6. Failure Diagnosis Table

As a troubleshooting aide, the table in **Fig. 8** lists possible failure symptoms, possible causes and solutions to assist in correcting the problem.

Symptoms	Possible Cause	Solution
Compressor does not work	Fuse or relay defective	Replace fuse or relay
	Magnetic clutch burned	Replace clutch
	Compressor locked	Replace compressor
	Low pressure switch open	Low on refrigerant or defective pressure switch
HP switch opens	Overcharge of refrigerant	Adjust refrigerant charge
	Condenser coil dirty	Clean condenser coil
	Condenser motor(s) not working	Replace motors(s)
	Faulty HP switch	Replace HP switch
LP switch opens	Loss of refrigerant	Check for possible leak, adjust charge
	Plugged or defective expansion valve	Replace the expansion valve
	Dirty evaporator coil	Clean the evaporator coil
	Dirty air filter	Clean or replace air filter
	Evaporator blower(s) not working	Replace fan motor(s)
	Faulty low pressure switch	Replace low pressure switch
Condenser motor not working	Electrical wiring connection bad	Locate and repair connection
	Burned fuse or defective control relay	Replace fuse and/or relay
	Open winding in motor	Replace motor
Evaporator motor not working	Electrical wiring connection bad	Locate and repair connection
	Burned fuse or defective control relay	Replace fuse and/or relay
	Open winding in motor	Replace motor

**Fig. 8 Failure Diagnosis Table**

Symptoms	Possible Cause	Solution
AC does not cool and Compressor remains on	Low on refrigerant charge	Check for leaks, adjust charge
	Non-Condensables in system	Evacuate the unit to 1000 microns or less and adjust charge to correct amount
	Plugged or defective expansion valve	Replace the expansion valve
	Dirty evaporator coil	Clean the coil
	Dirty air filters	Clean or replace air filters
AC cools down too much and Compressor continues to run	Incorrect temperature set point selection	Adjust desired set point temperature on control panel
	Temperature sensor location	Check and relocate temperature sensor
High discharge pressure	Overcharge of refrigerant in system	Adjust charge to correct amount
	Restriction in sealed system	Locate and remove restriction, compressor valve partially closed, expansion valve partially closed, filter drier plugged
	Condenser motor not working	Refer to symptom "Condenser motor not Working"
	Dirty condenser coil	Clean condenser coil
Low suction pressure	Low system charge	Check for leak, adjust charge
	Return air temperature too low	Relocate temperature sensor
	Plugged or defective expansion valve	Replace the expansion valve
	Evaporator motor not working	Refer to symptom "Evaporator motor not Working"
	Restriction in sealed system	Locate and remove restriction
	Dirty air filters	Clean or replace air filters
	Dirty evaporator coils	Clean evaporator coils

Fig. 8 Failure Diagnosis Table

## 7. Electrical Schematics of Relay Board for Manual Control Panel

### 7.1 12V Relay and Fuse Locations

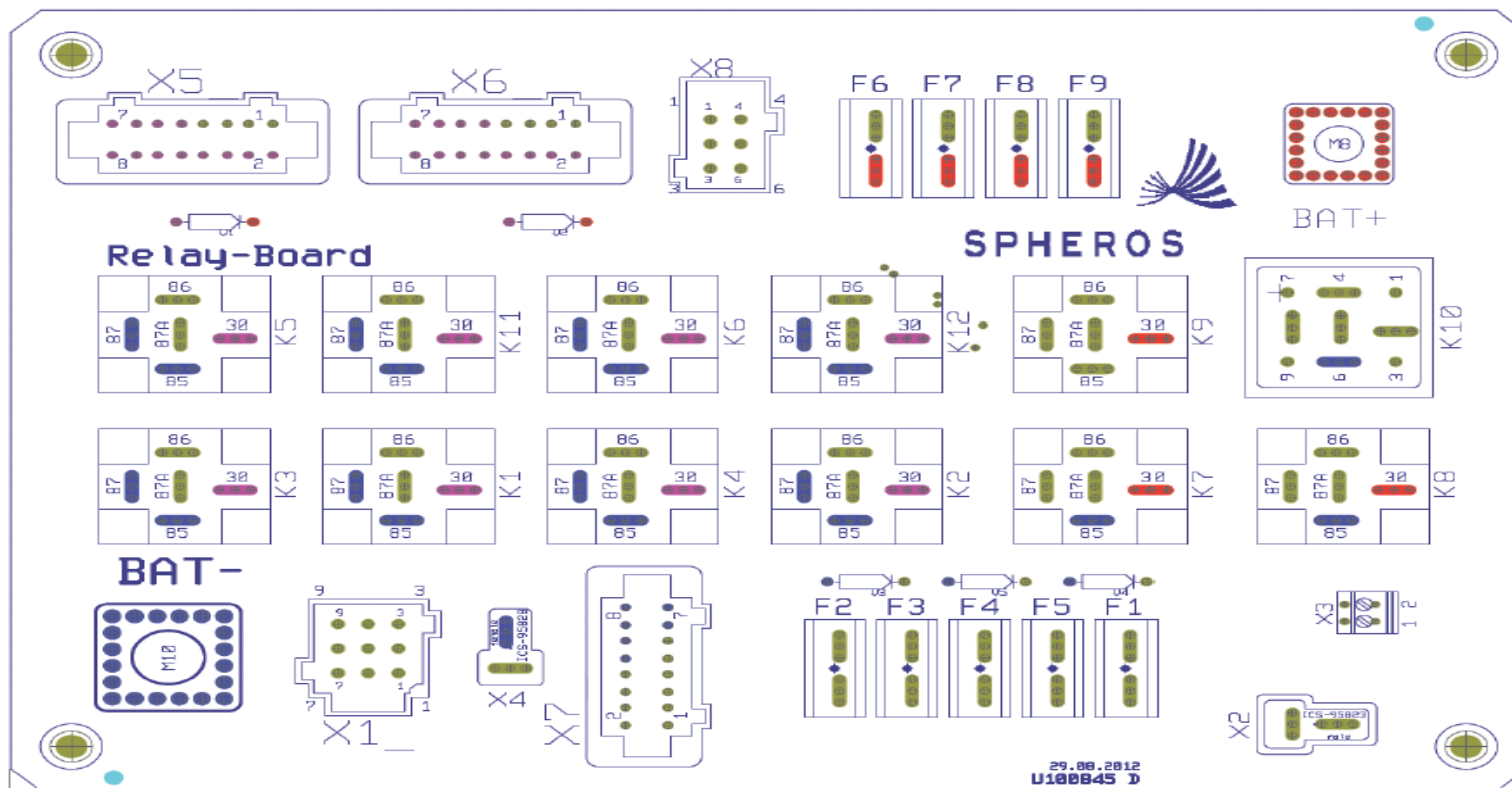

RELAY	FUNCTION	TYPE
K1	Blower Fan 1 – High Speed	40A
K2	Blower Fan 3 – High Speed	40A
K3	Blower Fan 2 – High Speed	40A
K4	Blower Fan 4 – High Speed	40A
K5	Blower Fans 1 & 2 – Med. Speed	40A
K6	Blower Fans 3 & 4 – Med. Speed	40A
K7	Condenser Fan 1 & Clutch Switch	40A
K8	Condenser Fan 2	40A
K9	Condenser Fan 3	40A
K10	Control relay	11115103A
K11	Blower Fans 1 & 2 Low Speed	40A
K12	Blower Fans 3 & 4 Low Speed	40A

FUSE	FUNCTION	TYPE
F1	Dash Control Unit	ISO8820 – 5A
F2	Clutch	ISO8820 – 10A
F3	Condenser Fan 1	ISO8820 – 25A
F4	Condenser Fan 2	ISO8820 – 25A
F5	Condenser Fan 3	ISO8820 – 25A
F6	Blower Fan 1	ISO8820 – 25A
F7	Blower Fan 2	ISO8820 – 25A
F8	Blower Fan 3	ISO8820 – 25A
F9	Blower Fan 4	ISO8820 – 25A

## 7.2 Relay Board Schematic for Manual Control Panel

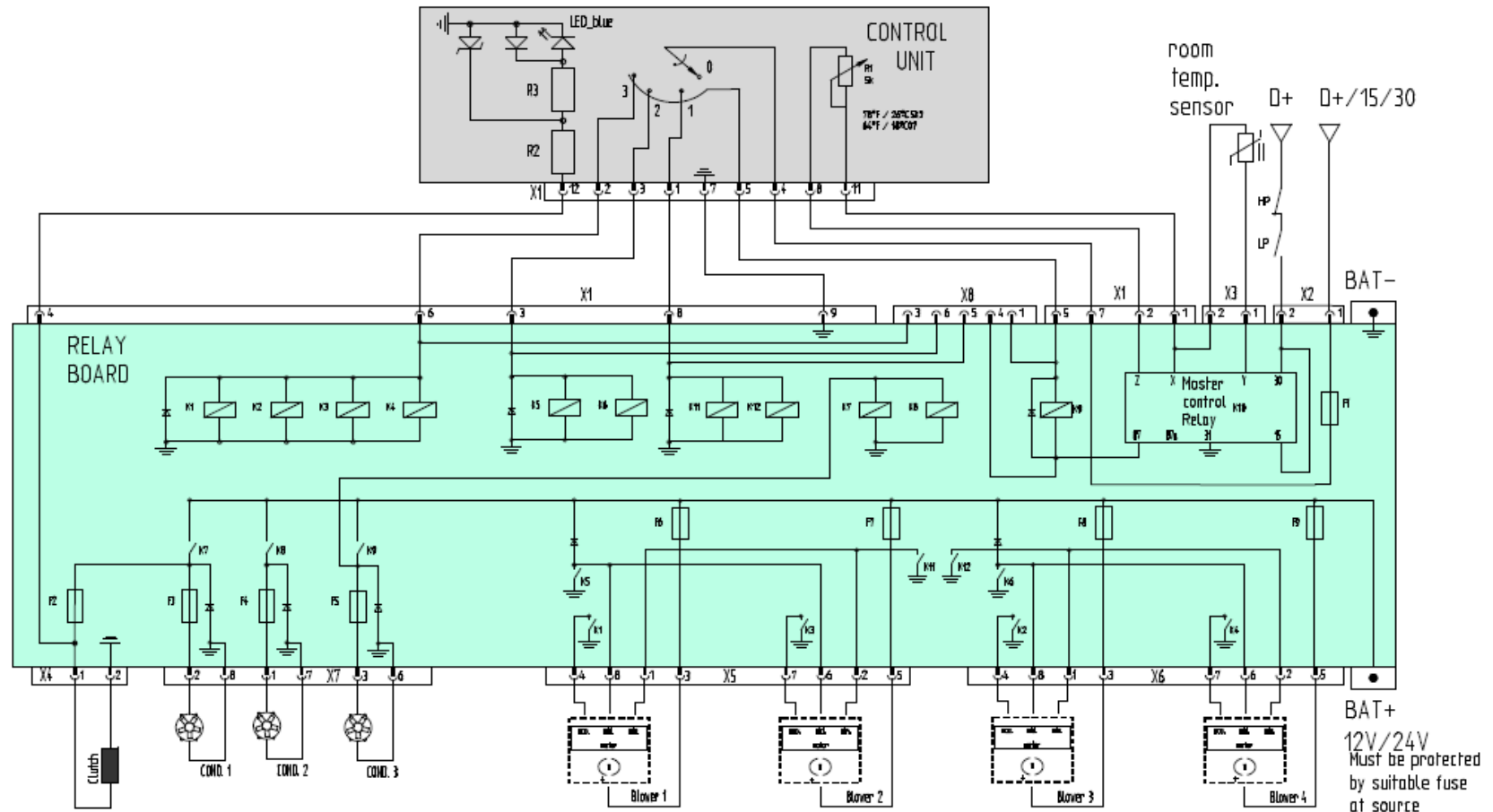

noting connectors

X1 ( 9 pin ) Tyco 1-967621-\*

X2 Tyco 180907 series

X4 Tyco 180908 series

X5 - X7 6+H 8 pin

LEAR DPK 1 + DPK 2 series (old No: 161B+ 1

Pueplichulsen-Ho: 7048645626210

X8 ( 6 pin ,P1 ) Tyco 1-965640-\*

Signal Availability			X2 pin 1 input connected to		
D+ (Clamp 61)	Ignition stage 1 (Clamp 15)	Battery + (Clamp 30)	D+ (Clamp 61)	Ignition stage 1 (Clamp 15)	Battery + (Clamp 30)
OFF	OFF	ON	no function	no function	no AC only ventilation
OFF	ON	ON	no function	no AC only ventilation	no AC only ventilation
ON	ON	ON	AC	AC	AC

Fuses	12V	24V
F1	5A	5A
F2	10A	10A
F3, F9	25A	25A

BAT+  
12V/24V  
Must be protected  
by suitable fuse  
at source

## 8 Electrical Schematic for Digital Control Panel and Relay Board

### 8.1 Control Panel

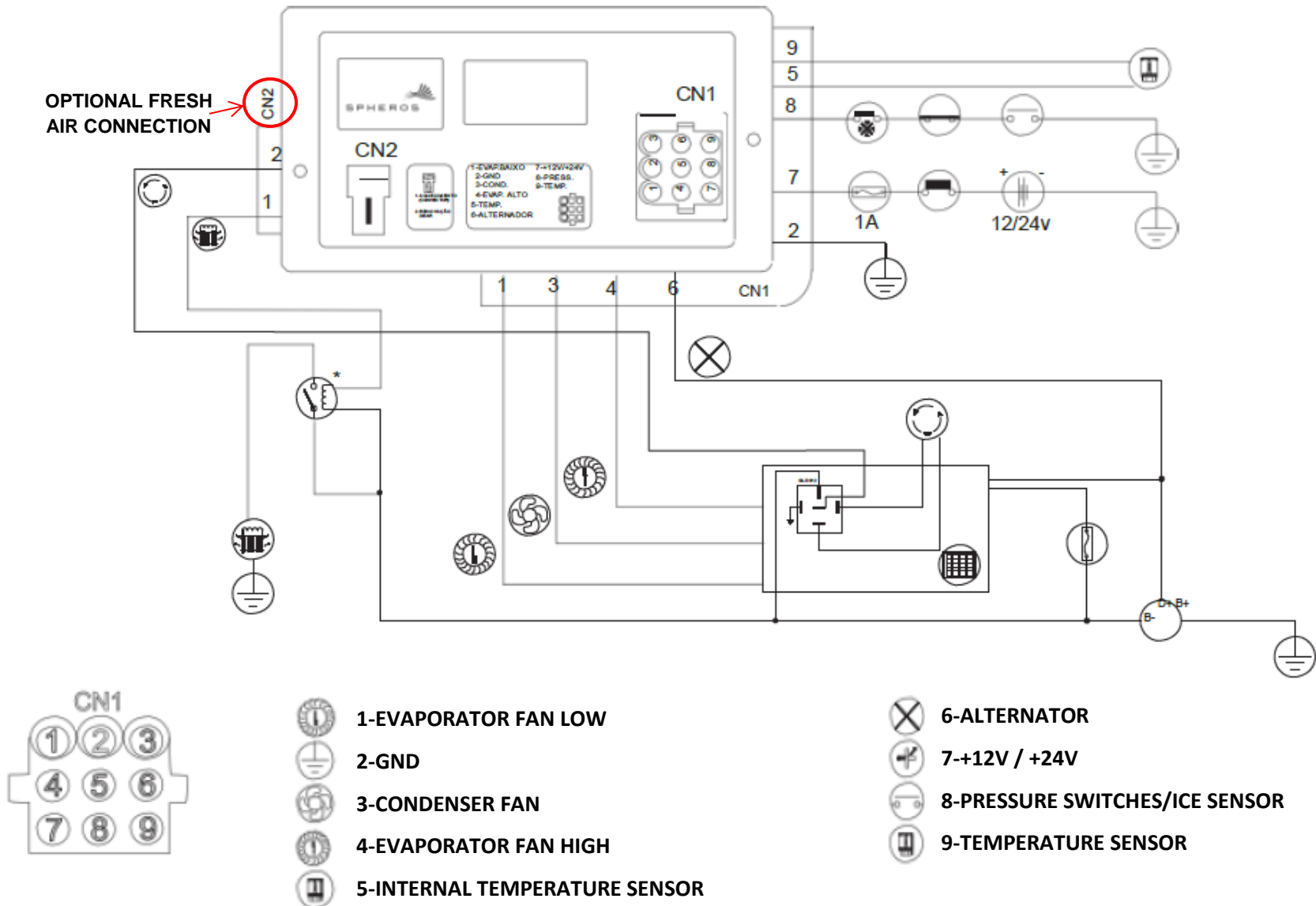

### 8.2 Relay Board Layout (12V)

RELAISTAFEL / RELAY BOARD 12 V

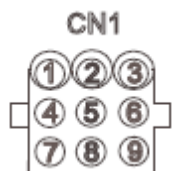

- 1. Condenser Fan **ON**
- 2. Condenser Fan **1**
- 3. Evaporator Blower **1 LO**
- 4. Evaporator Blower **ON HI**
- 5. Evaporator Blower **ON LO**
- 6. N.C.
- 7. N.C.
- 8. Evaporator Blower **1 HI**
- 9. D+

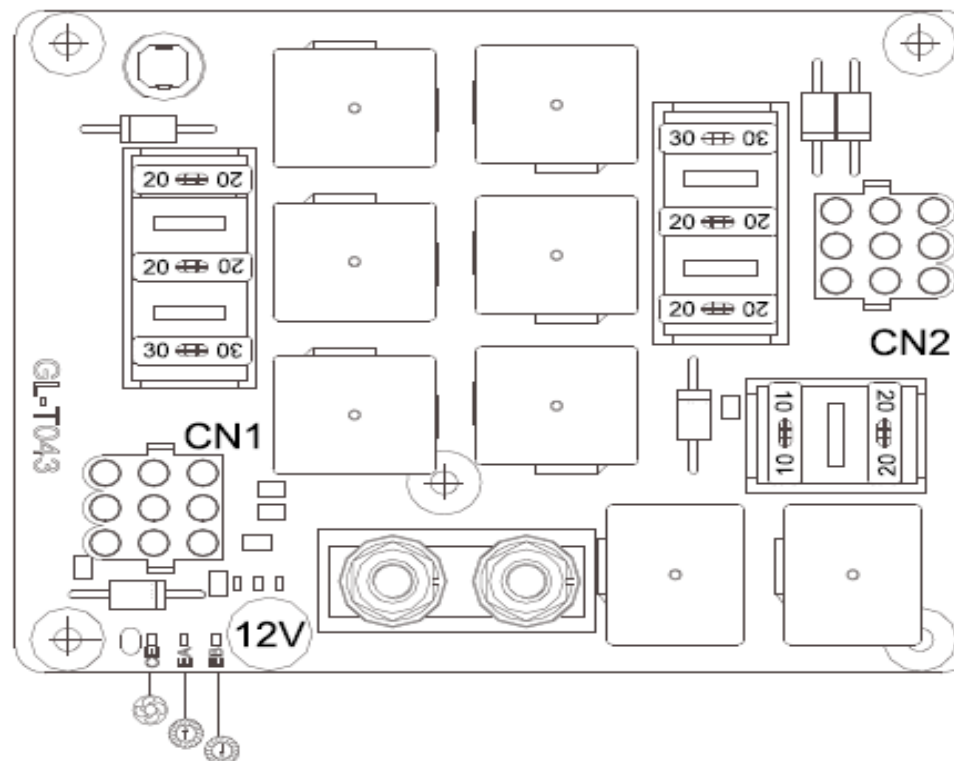

- 1. N/C
- 2. Condenser Fan **2**
- 3. Clutch / Solenoid Valve
- 4. Ground
- 5. Feed **12V**
- 6. N.C.
- 7. Evaporator Blower **2 HI**
- 8. Evaporator Blower **2 LO**
- 9. N.C.

Fuse	Function	Type
F1	Evaporator Blower 1 LO	20A
F2	Evaporator Blower 1 HI	30A
F3	Condenser Fan 1	20A
F4	N.C	
F5	Evaporator Blower 2 LO	20A
F7	Evaporator Blower 2 HI	30A
F8	Compressor Clutch / Solenoid Valve	10A
F9	Condenser Fan 2	20A



### 8.3 Wiring Schematic

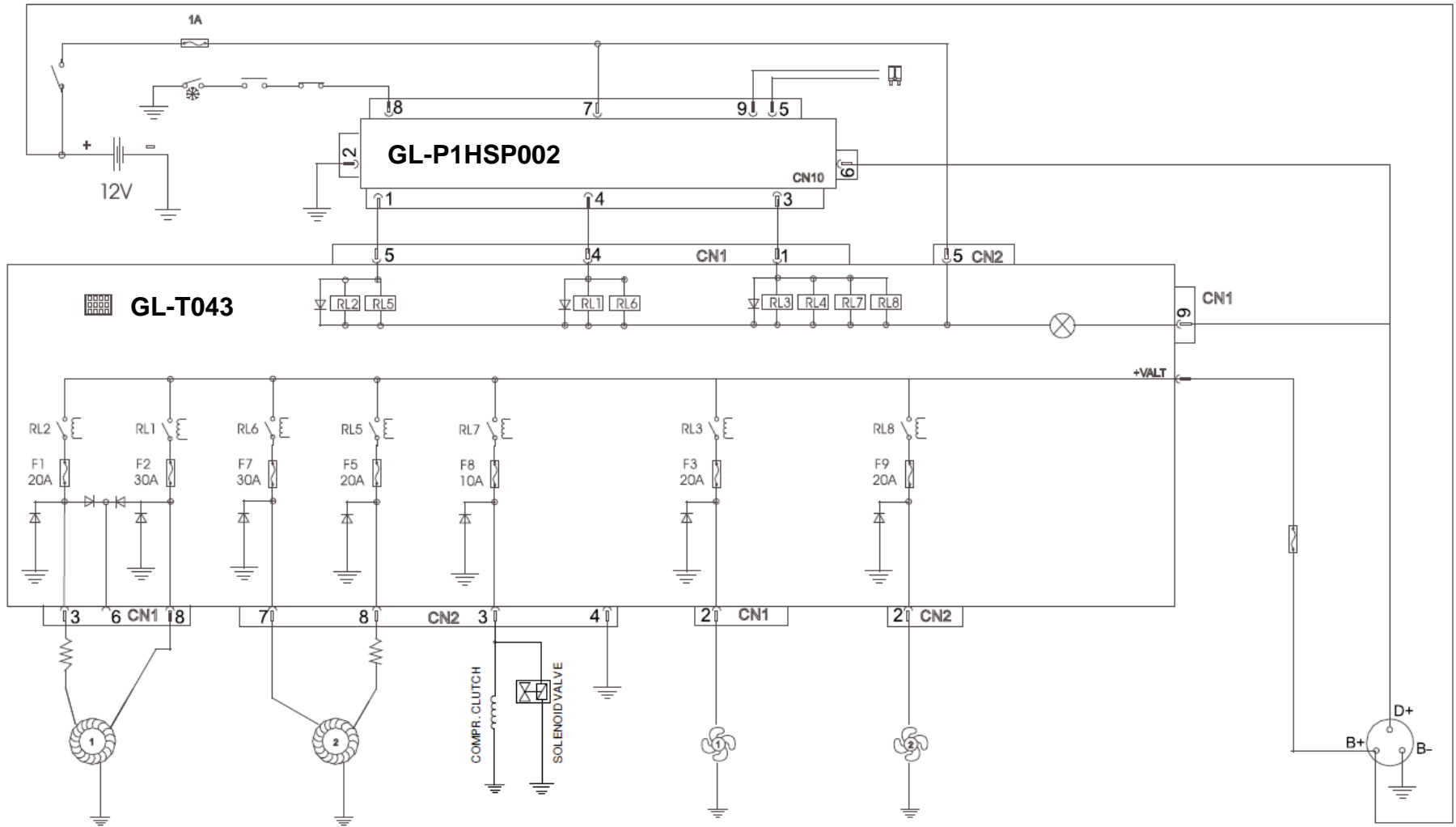

### 8.4 Wiring Schematic With Noise Suppression Relay

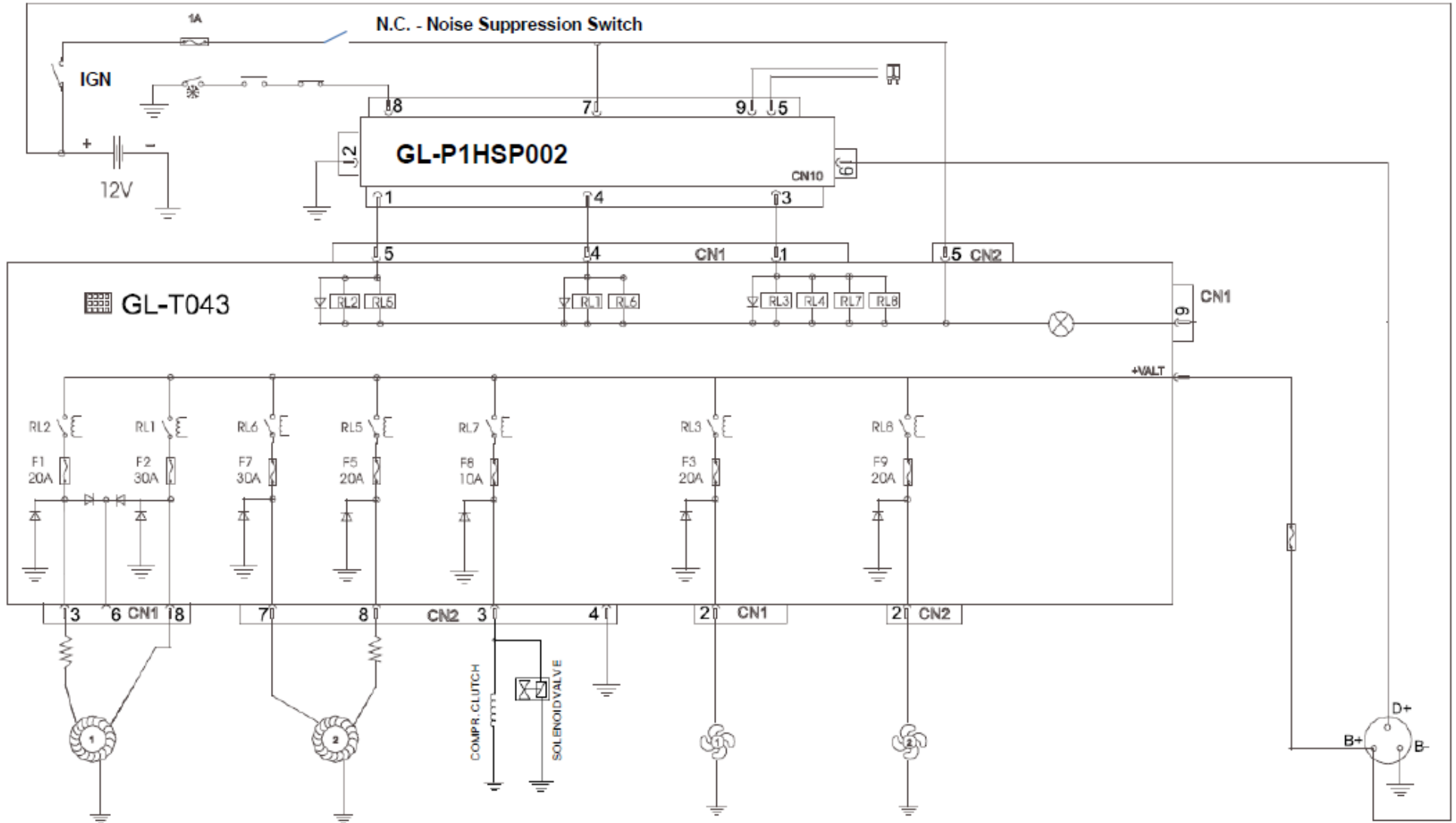

Spheros Climate Systems, LLC.  
5536 Research Drive  
Canton, MI 48188 USA  
Phone 1-734-218-7350 Toll free 1-888-960-4849  
Fax 1-734-487-1569  
[www.spheros.us](http://www.spheros.us)

