

Bill of Materials Listing

TransArctic Canada Inc.

7/19/2016
Page 1 of 1

Product Number	Description	Date	Weight	Uof M	Yield
Line	Component Prod#	Unit	Qty		
KMC61971	Mt Kit, ISB, 6.7L, BBCV, TM-31, '13-'16	9/24/2013	44.94		0
10	BEL61468	Belt, 6gr, 1468mm (57.8") (5060578)	each	1	
20	BMC67063	Bkt, Alt, Bar, ISB, F400, BBCV, '10	each	1	
30	BMC67069	Bkt, Angle, Brace, Hanger, Hose, 2010	each	2	
40	BMC67071	Bkt, Main, 6.7L, ISB, TM-55, BBCV, '10	each	1	
50	BMC67104	Bkt, Adapter, PL, ISB, TM-31, BBCV, '13	each	1	
70	BMC67105	Bkt, Shroud, Cover, ISB, TM-43/31, '10-'13	each	1	
75	BMC67107	Bkt, Spacer, Pl, TM-65/55/43, .06", ALUM	each	2	
80	BMC67126	Bkt, Main, V Weldmt, TM-65/55/43/31, '13	each	1	
90	BMZ00028	Bkt, Universal Hose & Cable	each	1	
100	BMZ00029	Bkt, Univer, Hose/Cable, MT, U/S Chassis	each	1	
110	CLP20001	Clamp, Gear, #20, 3/4-1 3/4 (19/44mm), S	each	2	
115	SCD25410	Spacer, Col, Drl, 25.4mm x 25.4o x 10.3i	each	4	
120	TEN80001	Tenr, HD Spring, BackSide, CW (89200D)	each	1	
130	KBC61971	Bag Kit, Fasteners, KMC61971	each	1	

NOTES:

- 1) The "TURBO TUBE" is rotated "END TO END" when re-installing it back onto the bus.
- 2) Belt runs in the "FRONT 6 grooves" of the compressor pulley.
- 3) Use blue "Loctite" when installing the (2) Alternator bolts.

Bill of Materials Listing

TransArctic Canada Inc.

4/4/2016
Page 1 of 1

Product Number		Description	Bin	Date	Weight	Uof M	Yield
Line	Component Prod#	Description		Unit	Qty		
KBC61971		Bag Kit, Fasteners, KMC61971		4/8/2011	2.37		0
5	BTC08025	Bolt, Hex, 8 x 1.25 x 25mm, 10.9, Plt		each	1		
10	BTC08030	Bolt, Hex, 8 x 1.25 x 30mm, 10.9, Plt,FT		each	2		
30	BTC10025	Bolt, Hex, 10 x 1.5 x 25mm, 10.9, Plt		each	7		
40	BTC10030	Bolt, Hex, 10 x 1.5 x 30mm, 10.9, Plt		each	1		
45	BTC10055	Bolt, Hex, 10 x 1.5 x 55mm, 10.9, Plt,FT		each	4		
50	BTC10070	Bolt, Hex, 10 x 1.5 x 70mm, 10.9, Plt		each	4		
55	BTC10090	Bolt, Hex, 10 x 1.5 x 90mm, 10.9, Plt		each	1		
60	BTC10140	Bolt, Hex, 10 x 1.5 x 140mm, 10.9, Plt		each	2		
90	CSF08031	Capscrew, FH, 8 x 1.25 x 30mm, 10.9,Plt		each	2		
100	CSF10026	Capscrew, FH, 10 x 1.5 x 25mm, 10.9,Plt		each	4		
105	NTA08000	Nut, Hex, 8 x 1.25, 8.8, Plt		each	1		
110	NTA10000	Nut, Hex, 10 x 1.5, 8.8, Plt		each	2		
120	WFA08000	Washer, Flat, 8mm, 8.8, Plt		each	3		
130	WFA10000	Washer, Flat, 10mm, 8.8, Plt		each	19		
150	WLA08000	Washer, Lock, 8mm, 8.8, Plt		each	3		
160	WLA10000	Washer, Lock, 10mm, 8.8, Plt		each	18		

8 7 6 5 4 3 2 1

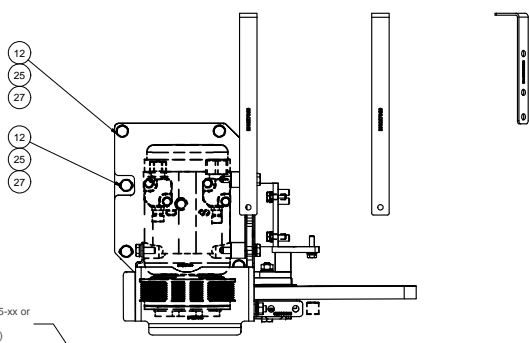

NOTE: USES Carrier# 76-62005-xx or
QUE# QP31-1213
(** Valco# 103-68540 **)

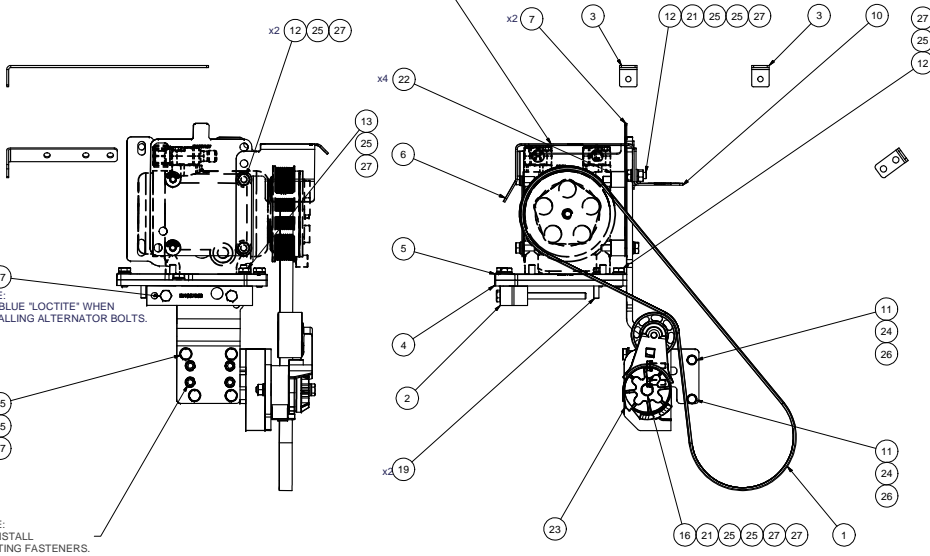

x2 17
NOTE:
USE BLUE "LOCTITE" WHEN
INSTALLING ALTERNATOR BOLTS.

NOTE:
RE-INSTALL
EXISTING FASTENERS.

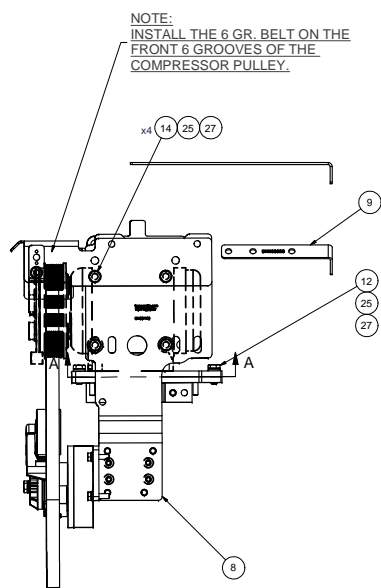

NOTE:
INSTALL THE 6 GR. BELT ON THE
FRONT 6 GROOVES OF THE
COMPRESSOR PULLEY.

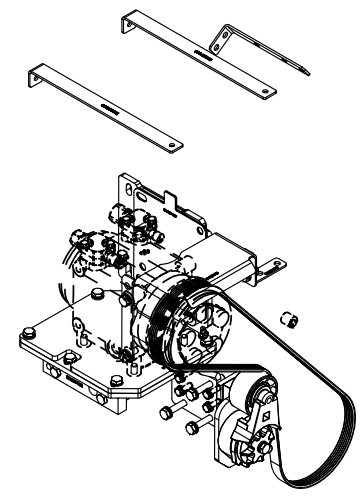

ISOMETRIC VIEW

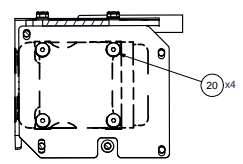

SECTION A-A

ITEM	QTY	U/M	PART NUMBER	DESCRIPTION
27	18	EACH	WLA10000	WASHER, LOCK, 10mm, 8.8, PLT
26	2	EACH	WLA08000	WASHER, LOCK, 8mm, 8.8, PLT
25	19	EACH	WFA10000	WASHER, FLAT, 10mm, 8.8, PLT
24	2	EACH	WFA08000	WASHER, FLAT, 8mm, 8.8, PLT
23	1	EACH	TEN80001	TENR, HD SPRING, BACKSIDE, CW
22	4	EACH	SCD25410	SPACER, COL, DRL, 25.4mm x 25.40 x 10.31
21	2	EACH	N1A10000	NUT, HEX, 10 x 1.5, 8.8, PLT
20	4	EACH	CSF10026	CAPSCREW, FH, 10 x 1.5 x 25mm, 10.9, PLT
19	2	EACH	CSF08031	CAPSCREW, FH, 8 x 1.25 x 30mm, 10.9, PLT
18	2	EACH	CLP20001	CLAMP, GEAR, #20, 3/4-1 3/4 (19/44mm)
17	2	EACH	BTC10140	BOLT, HEX, 10 x 1.5 x 140mm, 10.9, PLT
16	1	EACH	BTC10090	BOLT, HEX, 10 x 1.5 x 90mm, 10.9, PLT
15	4	EACH	BTC10070	BOLT, HEX, 10 x 1.5 x 70mm, 10.9, PLT
14	4	EACH	BTC10055	BOLT, HEX, 10 x 1.5 x 55mm, 10.9, PLT
13	1	EACH	BTC10035	BOLT, HEX, 10 x 1.5 x 35mm, 10.9, PLT
12	7	EACH	BTC10025	BOLT, HEX, 10 x 1.5 x 25mm, 10.9, PLT
11	2	EACH	BTC08030	BOLT, HEX, 8 x 1.25 x 30mm, 10.9, PLT
10	1	EACH	BMZ00029	BKT, UNIVER, HOSE/CABLE, MT, U/S CHASSIS
9	1	EACH	BMZ00028	BKT, UNIVERSAL HOSE & CABLE CLAMP
8	1	EACH	BMC67126	BKT, MAIN, V Weldmt, TM-65/55/43/31, '13
7	2	EACH	BMC67107	BKT, SPACER PL, TM-65/55, .06", ALUM
6	1	EACH	BMC67105	BKT, SHROUD, COVER, ISB, TM-43/31, '10-'13
5	1	EACH	BMC67104	BKT, ADAPTER, PL, ISB, TM-31, BBCV, '13
4	1	EACH	BMC67071	BKT, MAIN, 6.7L, ISB, F400, BBCV, 10
3	2	EACH	BMC67069	BKT, ANGLE, BRACE, HANGER, HOSE, 2010
2	1	EACH	BMC67063	BKT, ALT, BAR, ISB, F400, BBCV, 10
1	1	EACH	BEL1468	BELT, 6Gr, 1468mm (57.8") (50x0578)

TRANSARGTIG INC.

TITLE: **MT KIT, ISB, 6.7L, BBCV, TM-31, '13-16**

DATE: 3/23/2016

SCALE: 1:4

DWG NO: **KMC61971**

REV: 0

SHEET 1 OF 1

NOTES:
1) USE SERVICABLE THREADLOCKER ON ALL FASTENERS TO ENGINE COMPONENTS AND TORQUE ALL BOLTS TO S.A.E. SPECIFICATIONS.
2) SEE "TRANSARGTIG A/C COMPRESSOR MOUNT INSTALLATION DISCLAIMER".

REV	DESCRIPTION	DATE	BY
1	RELEASED TO PRODUCTION	3/23/2016	Val Jakowlew
2			James Stewart
3			James Stewart

UNSPECIFIED TOLERANCES:
ONE DECIMAL PLACE (X.0) .05 MM
TWO DECIMAL PLACE (X.00) .02 MM
THREE DECIMAL PLACE (X.000) .01 MM
FUNCTIONAL (X.150) .150 MM

THIRD ANGLE PROJECTION

DRAWING UNIT OF MEASURE: MM (INCH)

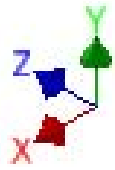

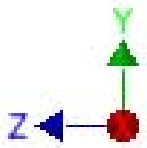
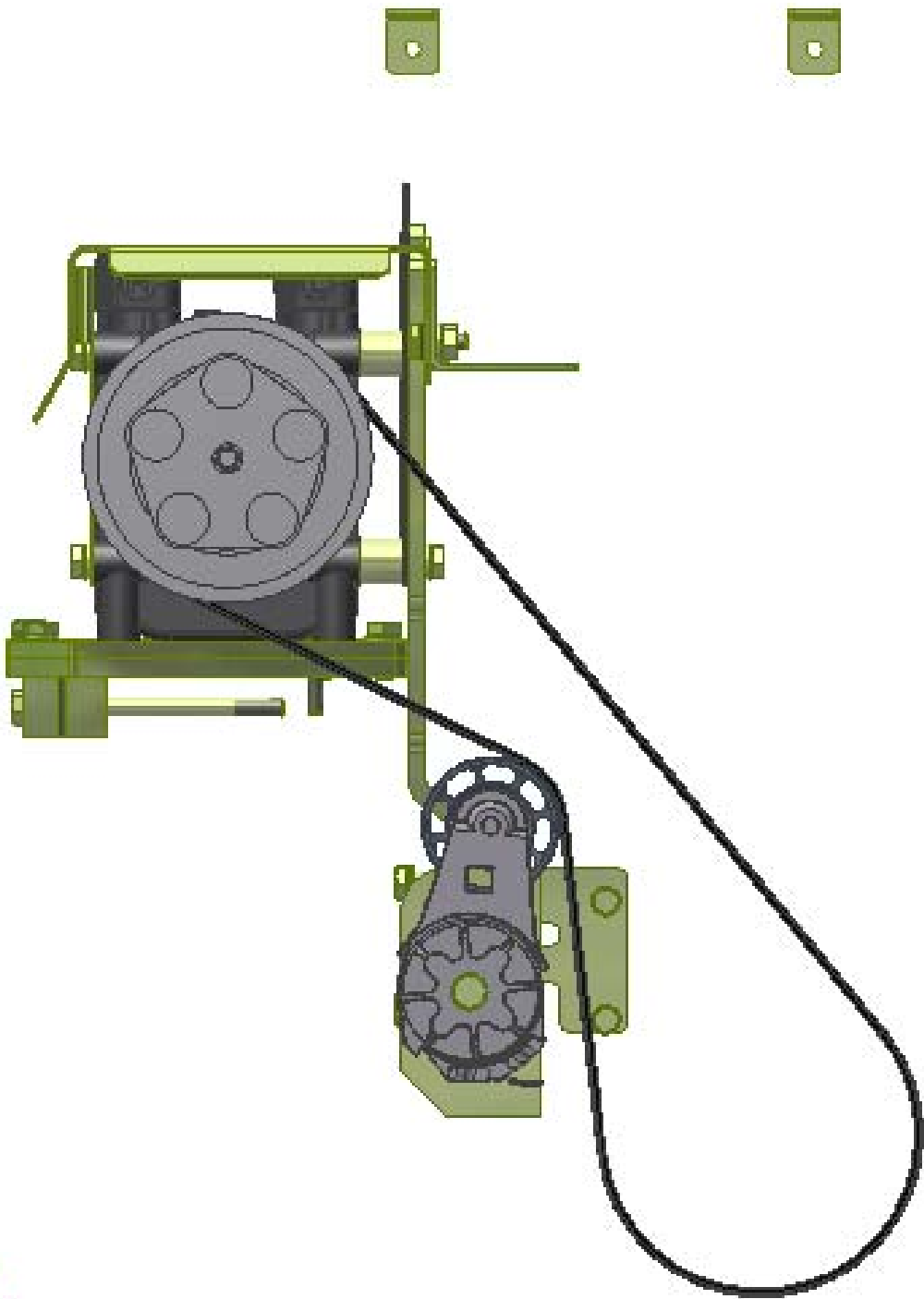

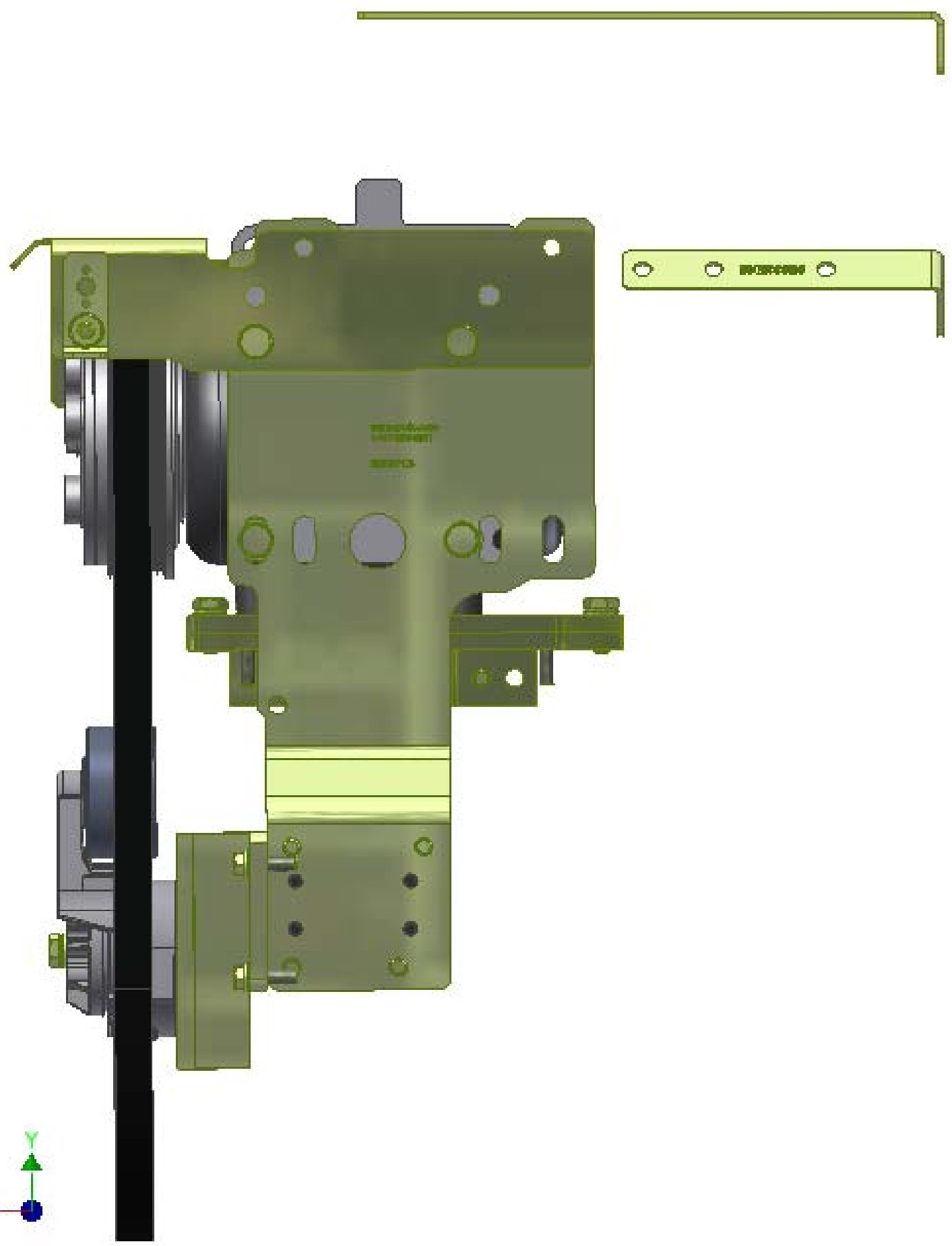
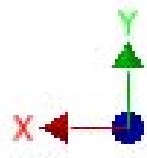

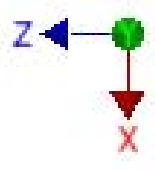
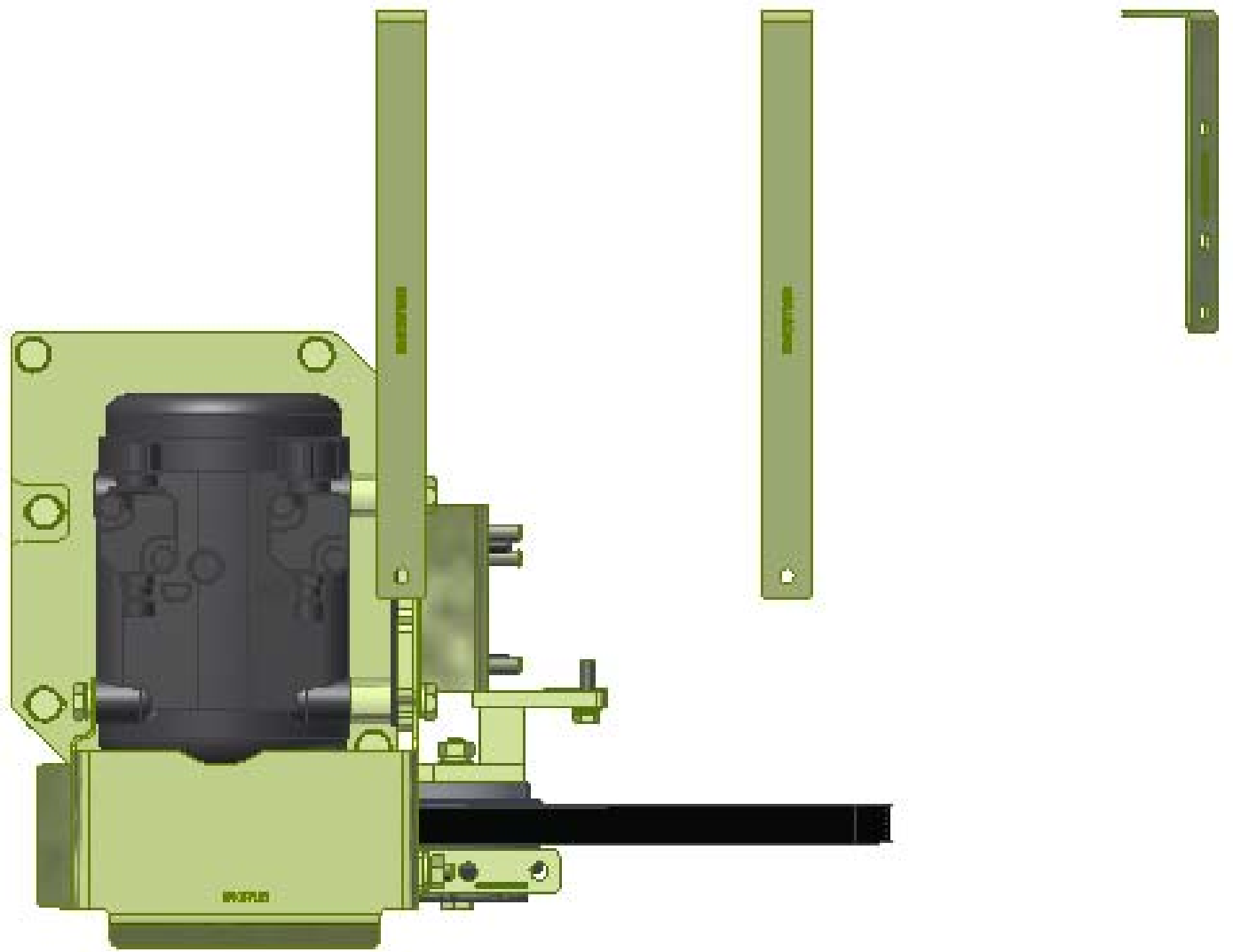

TransArctic A/C Compressor Mount Installation Disclaimer

All compressor mounts should be installed by qualified and trained personnel using proper tools and equipment in safe working conditions following industry standard guidelines for motor vehicle service and repair.

The installer of any compressor mount purchased from TransArctic must undertake all responsibility of issues arising from that compressor bracket being installed on any vehicle. As well as insure that a **proper and sufficient ground** is established between the compressors' clutches and the vehicle's engine. Mount functionality, operation and durability can all be compromised by an incompetent installation.

Due to the many different situations, parameters and application criteria, which are beyond the compressor mount manufacturer's control, TransArctic does not warrant design, durability, or operational functionality of any compressor mount improperly installed by another party.

With no implied guarantees it is the mount installer's strict responsibility to determine safety and functionality, of the compressor mount, at the time of installation.

Please contact TransArctic with any issue arising from installation so we may better improve the product. If you have any reservations about the compressor mount integrity contact TransArctic immediately at 1-877-COLD-AIR.

Mark OEM tensioner location

Install Kit

Check for Interferences

Check to ensure that the proper OEM tensioner orientation is maintained

Run engine with A/C system engaged for at least 10 minutes to run in belt

Check OEM tensioner orientation and adjust as required

Responsabilidad limitada de TransArctic en la instalación del soporte del compresor

Todos los soportes de los compresores deben ser instalados por personas calificadas y entrenadas, usando para ello los equipos y herramientas necesarios para esta labor en buenas condiciones y según las normas y guías para el servicio y/o reparación de motores de vehículos.

El instalador de los soportes comprados en TransArctic asume toda la responsabilidad de cualquier problema que surga en el soporte del compresor al vehículo; de igual manera es responsable que el cable a tierra sea conectado entre el embrague del compresor y el motor del vehículo.

Se advierte que el buen funcionamiento y la durabilidad del soporte pueden ser comprometidos por defectos en su instalación.

Debido a las diversas situaciones que se puedan presentar fuera del control del fabricante, TransArctic no garantiza el diseño, la durabilidad o el correcto funcionamiento de cualquier equipo inapropiadamente instalado por terceros.

Esta sobreentendido que el Instalador del montaje del compresor es estrictamente responsable de la seguridad y funcionamiento del equipo en el momento de la instalación.

Si tuviera algún problema o duda acerca de la instalación del soporte del compresor pongase en contacto inmediatamente con TransArctic al teléfono 1-877-COLD-AIR de modo que podamos mejorar nuestro producto.

Note la ubicación del medidor de tensión OEM

Instale el equipo

Controlar si hay interferencias.

Asegure que el medidor de tensión mantenga la orientación justa.

Encienda el motor por lo menos 10 minutos con el sistema A/C enganchado para que la correa corra

Controle la orientación justa del medidor de tensión y ajuste a las condiciones requeridas del fabricante