

TRANSARCTIC 1-877-GOLD-AIR



RTC34030 DUAL LOOP

SERVICE PARTS LIST

12V Rooftop Air Conditioning Unit
With Electronic Thermostat

Rev 25090

TABLE OF CONTENTS

INTRODUCTION.....	3
ORDERING INSTRUCTIONS AND RECOVERY/EVACUATION PROCEDURES.....	3, 4
CONDENSER ASSEMBLY.....	5
EVAPORATOR ASSEMBLY.....	6
FRAME AND INSULATION.....	7
COOLING SYSTEM COMPONENTS.....	8
EVAPORATOR AND CONDENSER COVERS.....	9
RETURN AIR FILTER AND FRAME.....	10
EVAPORATOR BLOWERS.....	11
ELECTRICAL RELAY PANEL.....	12
ELECTRONIC CONTROL AND OPERATIONS.....	13, 25
WIRE HARNESES	26
ELECTRICAL SCHEMATICS.....	27, 28
BILL OF MATERIALS.....	29, 34

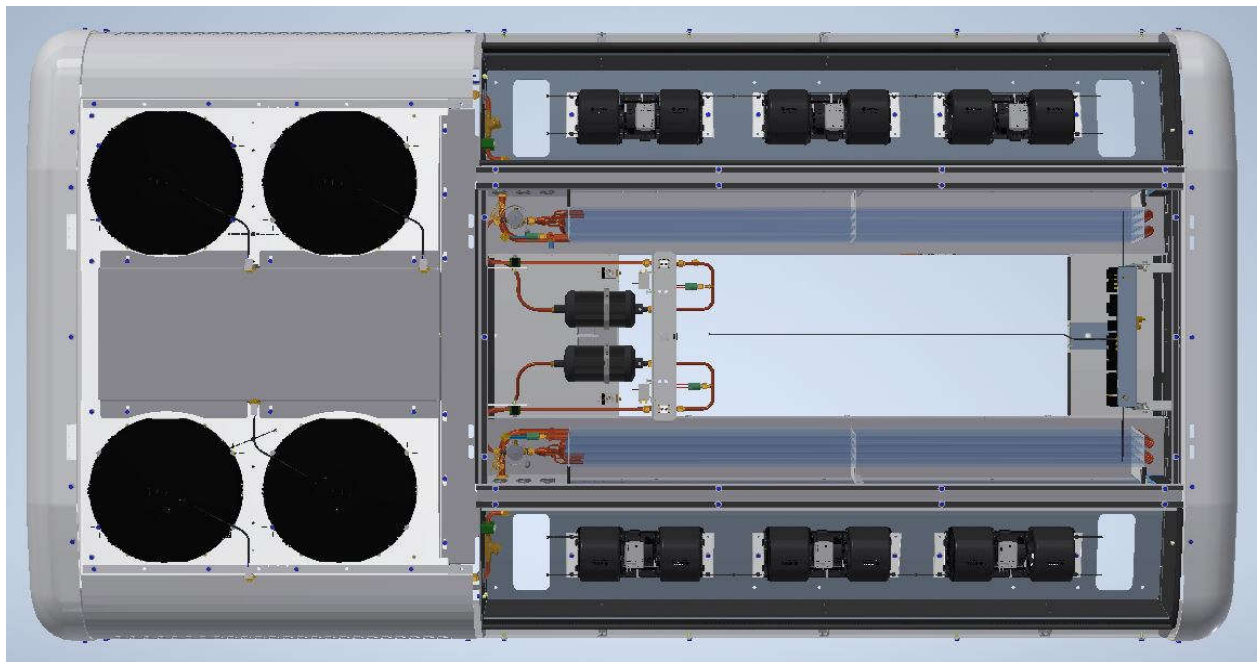

INTRODUCTION:

This system is a Dual TM21, Or Dual QP25, Or One TM43. 12VRooftop, 170,000 BTU (IMACA) 24.3KW. (ARI)

System Charge = 5.50lbs – R134A Refrigerant Per Side

System Lubricant: 8.00oz - PAG 46 Oil Per Side

Solenoid Warning – Solenoids must be manually opened using appropriate magnets during Recovery and Evacuation Procedures. See Following page for Instructions.

SERVICE PARTS ORDERING INSTRUCTIONS:

Orders must include: The Unit Serial Number, Part Number and quantity required along with part Description as shown on the parts list.

TransArctic of Southern Georgia.

101 Industrial Park Dr. Perry GA. 31069
478-822-1126 or 1-877-265-3247

System Sales

Dale Mason
dmason@transarctic.com

.....

Parts Sales

Rebecca Yeoman
ryeoman@transarctic.com

.....

Kevin Harris
kharris@transarctic.com

.....

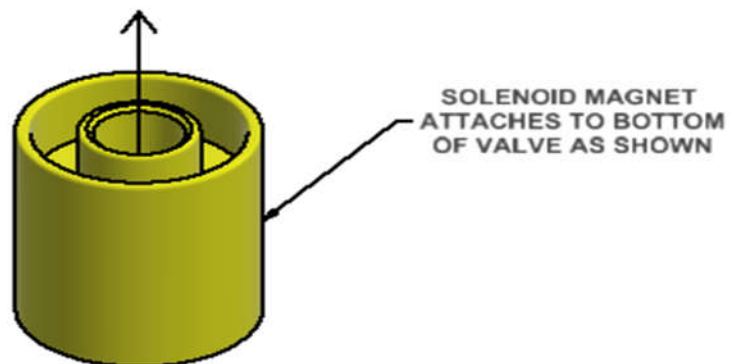
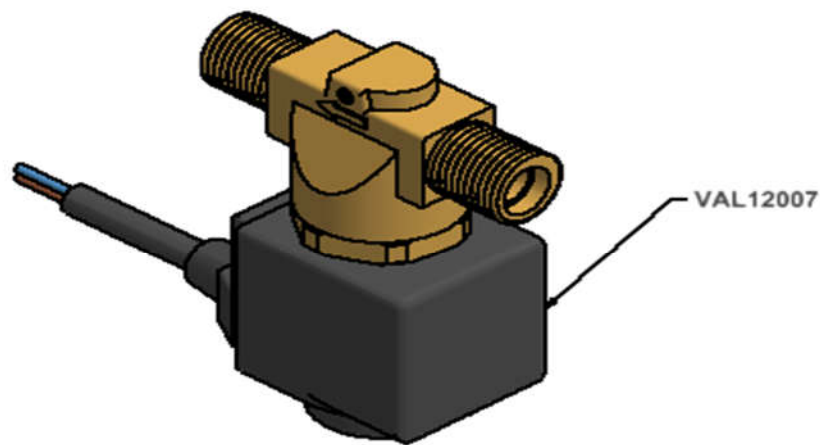
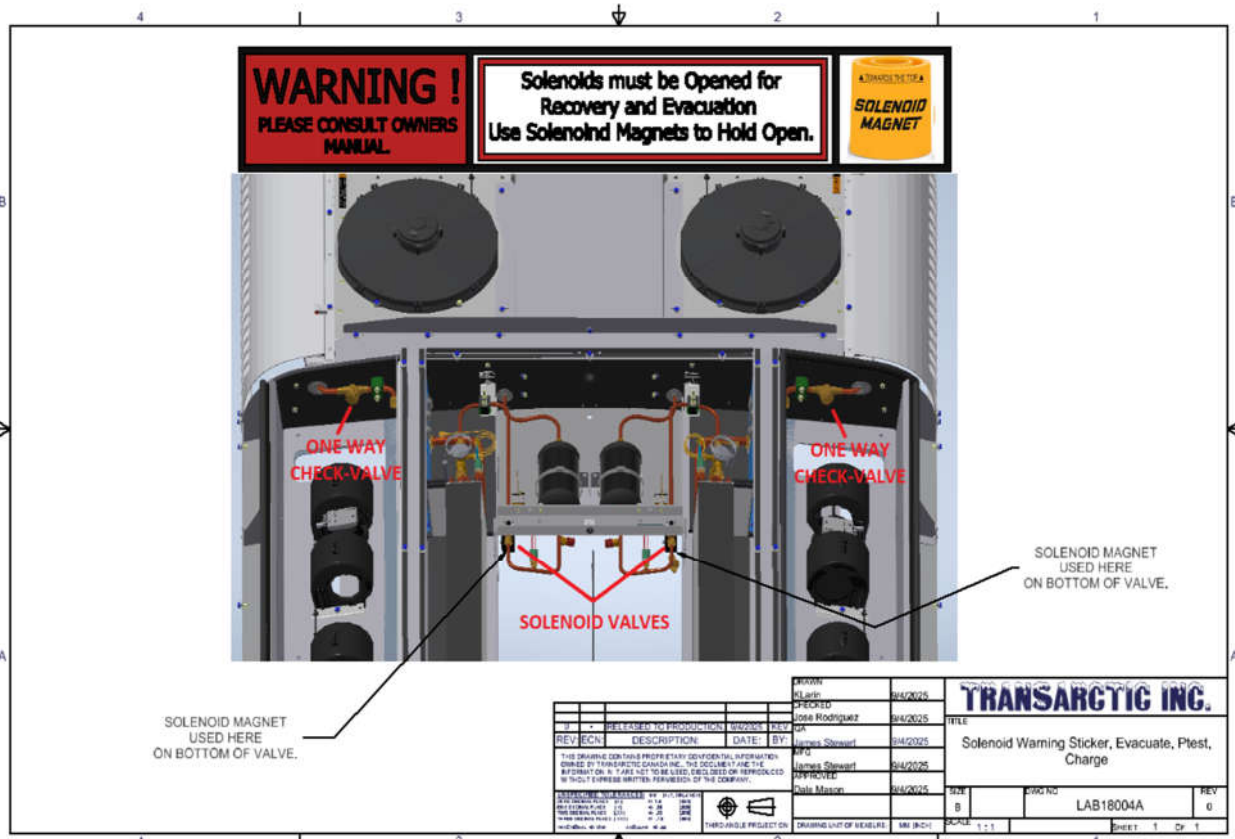

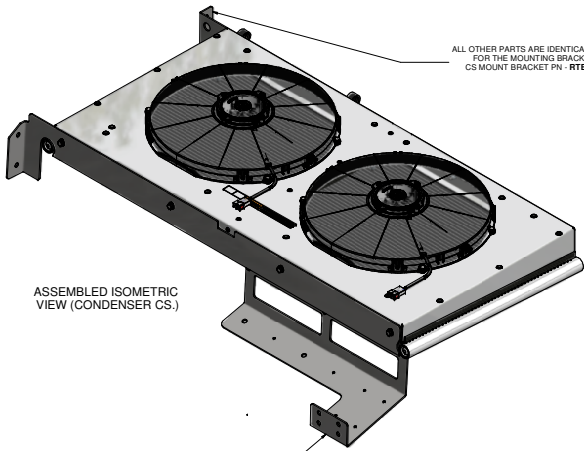

ALL OTHER PARTS ARE IDENTICAL EXCEPT FOR THE MOUNTING BRACKETS, CS MOUNT BRACKET PN - RTB18032

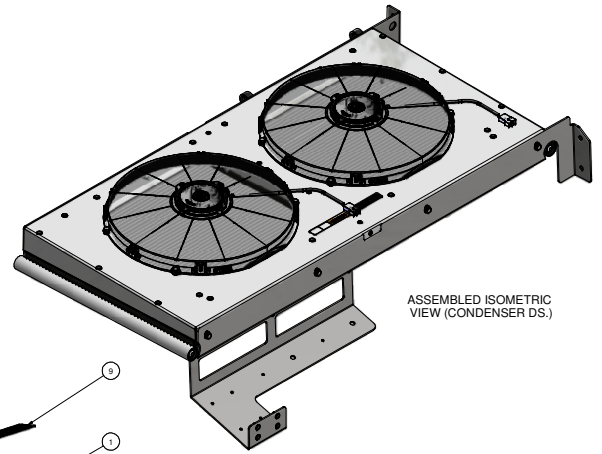

ASSEMBLED ISOMETRIC VIEW (CONDENSER DS.)

ALL OTHER PARTS ARE IDENTICAL EXCEPT FOR THE MOUNTING BRACKETS, CS MOUNT BRACKET PN - RTB18030

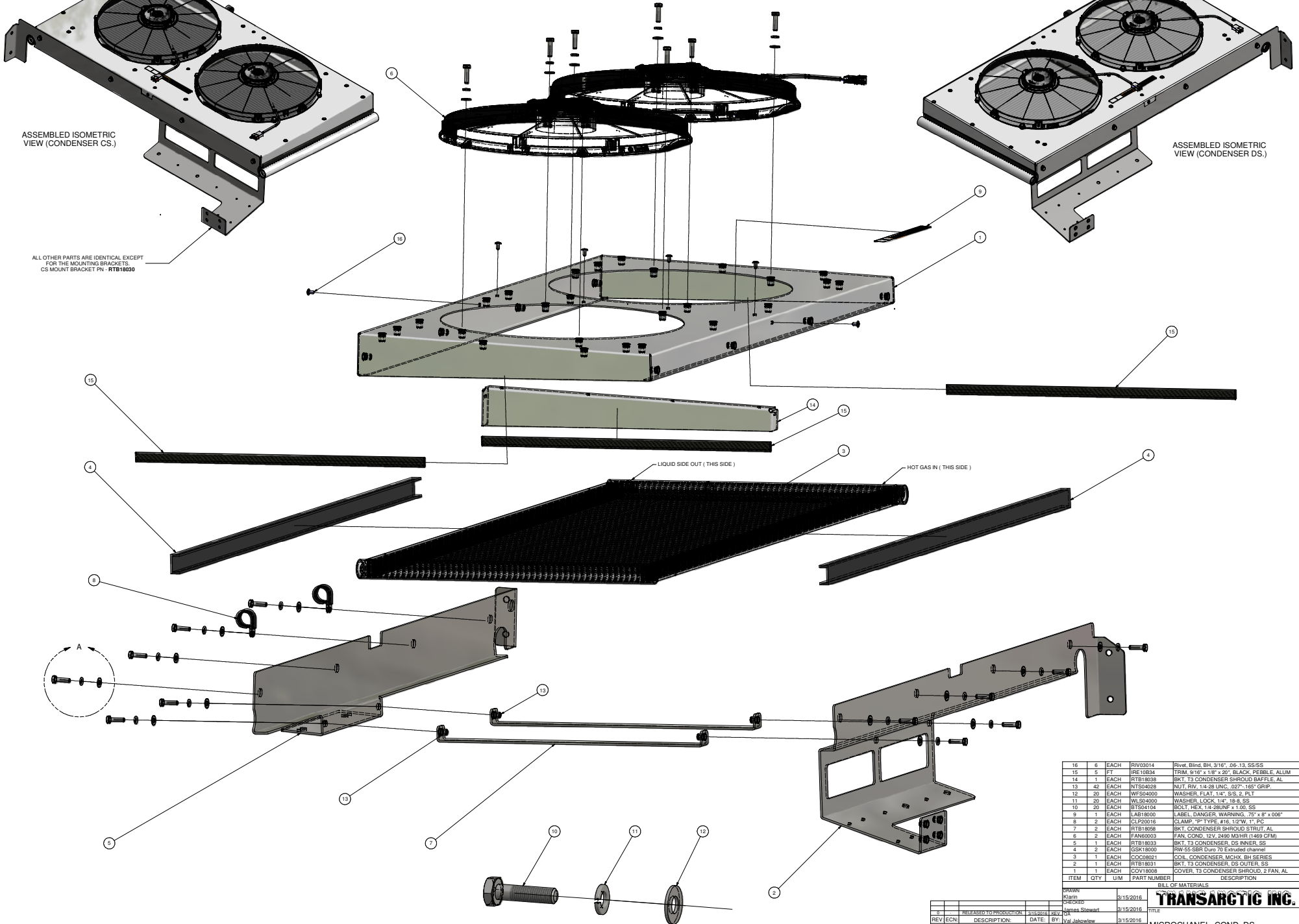

LIQUID SIDE OUT (THIS SIDE)

HOT GAS IN (THIS SIDE)

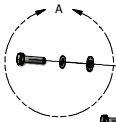

DETAIL A
SCALE 2 : 1

SUB ASSEMBLY

ITEM	QTY.	UM.	PART NUMBER	DESCRIPTION
16	6	EACH	RIV0014	Rivet Blind, BH, 3/16", 06-13, SS-SS
15	5	FT	IRE10B34	TRIM, 9/16" x 1/8" x 20", BLACK, PEBBLE, ALUM
14	1	EACH	RTB18038	BKT. T3 CONDENSER SHROUD BAFFLE, AL
13	42	EACH	NT504028	NUT, RIV, 1/4-28 UNC, 027"-165" GRIP
12	20	EACH	WFS04000	WASHER, FLAT, 1/4", SS, 2, P1
11	20	EACH	WLS04000	WASHER, LOCK, 1/4", 18-8, SS
10	20	EACH	BTS04104	BOLT, HEX, 1/4-28UNF x 1.00, SS
9	1	EACH	L4818000	LABEL, DANGER, WARNING, 75" x 8" x 006"
8	2	EACH	CLP20016	CLAMP, "P" TYPE, #16, 1/2"W, 1", PC
7	2	EACH	RTB18058	BKT. CONDENSER SHROUD STRUT, AL
6	2	EACH	FAN00003	FAN, COND, 20V, 3490 RPM, 11455 CFM, 1
5	1	EACH	RTB18033	BKT. T3 CONDENSER, DS INNER, SS
4	2	EACH	GSK18000	RW-SS-SBR Duro 70 Extruded channel
3	1	EACH	COO08021	COIL, CONDENSER, MCH, BH SERIES
2	1	EACH	RTB18031	BKT. T3 CONDENSER, DS OUTER, SS
1	1	EACH	COV18008	COVER, T3 CONDENSER SHROUD, 2 FAN, AL

DESIGN: Kiana
 CHECKED: Lyness Stewart
 DATE: 3/15/2016
 BY: JMA
 DATE: 3/15/2016
 APPROVED: Date Mason
 DATE: 3/15/2016

TRANSARC TIC INC.
 MICROCHANNEL, COND, DS, ASSEMBLY.

REV: 0
 DWG NO: CONDENSER, DS.
 SCALE: 1:2
 SHEET: 1 OF 1

REV	ECN	DESCRIPTION	DATE	BY
		REVISED TO PRODUCTION	3/15/2016	JMA

THIS DRAWING CONTAINS PROPRIETARY CONFIDENTIAL INFORMATION OWNED BY TRANSARC TIC COMPANY INC. THE DOCUMENT AND THE INFORMATION IN IT ARE NOT TO BE REPRODUCED, COPIED, OR REPRODUCED WITHOUT EXPRESS WRITTEN PERMISSION OF THE COMPANY.

UNSPECIFIED TOLERANCES: FIN. DIMS. ±0.004
 DIMENSIONAL FINISH: CLASS 1
 THREADS: PER ANSI B1.13-2M
 FINISH: PER ANSI B1.13-2M
 PROJECTION: FIRST ANGLE PROJECTION

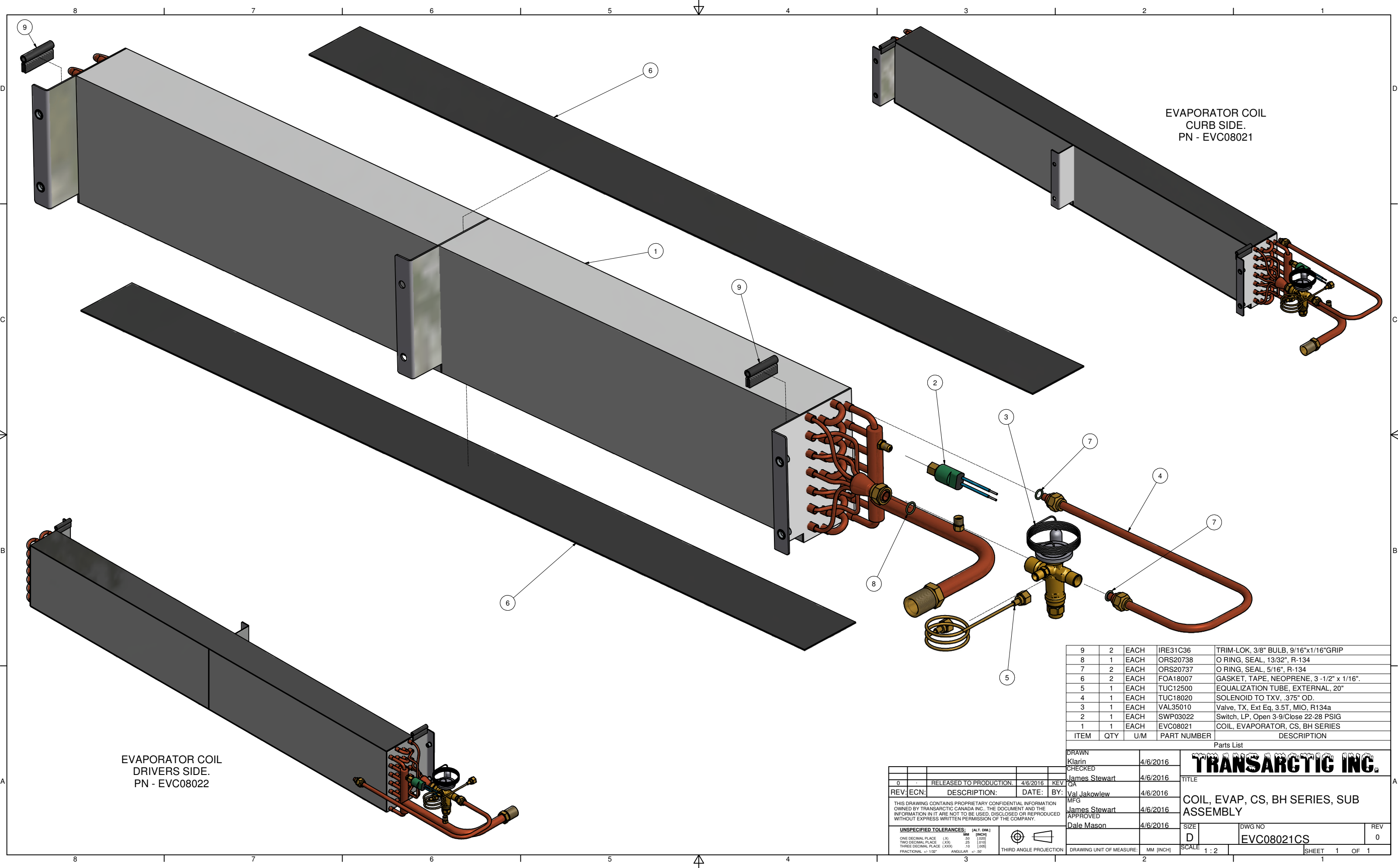

EVAPORATOR COIL
CURB SIDE.
PN - EVC08021

EVAPORATOR COIL
DRIVERS SIDE.
PN - EVC08022

ITEM	QTY	U/M	PART NUMBER	DESCRIPTION
9	2	EACH	IRE31C36	TRIM-LOK, 3/8" BULB, 9/16"x1/16"GRIP
8	1	EACH	ORS20738	O RING, SEAL, 13/32", R-134
7	2	EACH	ORS20737	O RING, SEAL, 5/16", R-134
6	2	EACH	FOA18007	GASKET, TAPE, NEOPRENE, 3 -1/2" x 1/16".
5	1	EACH	TUC12500	EQUALIZATION TUBE, EXTERNAL, 20"
4	1	EACH	TUC18020	SOLENOID TO TXV, .375" OD.
3	1	EACH	VAL35010	Valve, TX, Ext Eq, 3.5T, MIO, R134a
2	1	EACH	SWP03022	Switch, LP, Open 3-9/Close 22-28 PSIG
1	1	EACH	EVC08021	COIL, EVAPORATOR, CS, BH SERIES

Parts List

DRAWN	Klarin	4/6/2016
CHECKED	James Stewart	4/6/2016
REV: ECN:	DESCRIPTION:	DATE: BY:
	Val Jakowlew	4/6/2016
	James Stewart	4/6/2016
	Dale Mason	4/6/2016

TRANSARCTIC INC.

TITLE: COIL, EVAP, CS, BH SERIES, SUB ASSEMBLY

SIZE: D DWG NO: EVC08021CS REV: 0

THIS DRAWING CONTAINS PROPRIETARY CONFIDENTIAL INFORMATION OWNED BY TRANSARCTIC CANADA INC. THE DOCUMENT AND THE INFORMATION IN IT ARE NOT TO BE USED, DISCLOSED OR REPRODUCED WITHOUT EXPRESS WRITTEN PERMISSION OF THE COMPANY.

UNSPECIFIED TOLERANCES: (ALT. DIM) .001 (INCH) .025 (MM)

ONE DECIMAL PLACE (XX) .05 (INCH) .0125 (MM)

TWO DECIMAL PLACE (XXX) .01 (INCH) .025 (MM)

THREE DECIMAL PLACE (XXXX) .005 (INCH) .0125 (MM)

FRACTIONAL: 1/32" ANGULAR: +/- .50°

THIRD ANGLE PROJECTION

DRAWING UNIT OF MEASURE: MM [INCH] SCALE: 1:2 SHEET 1 OF 1

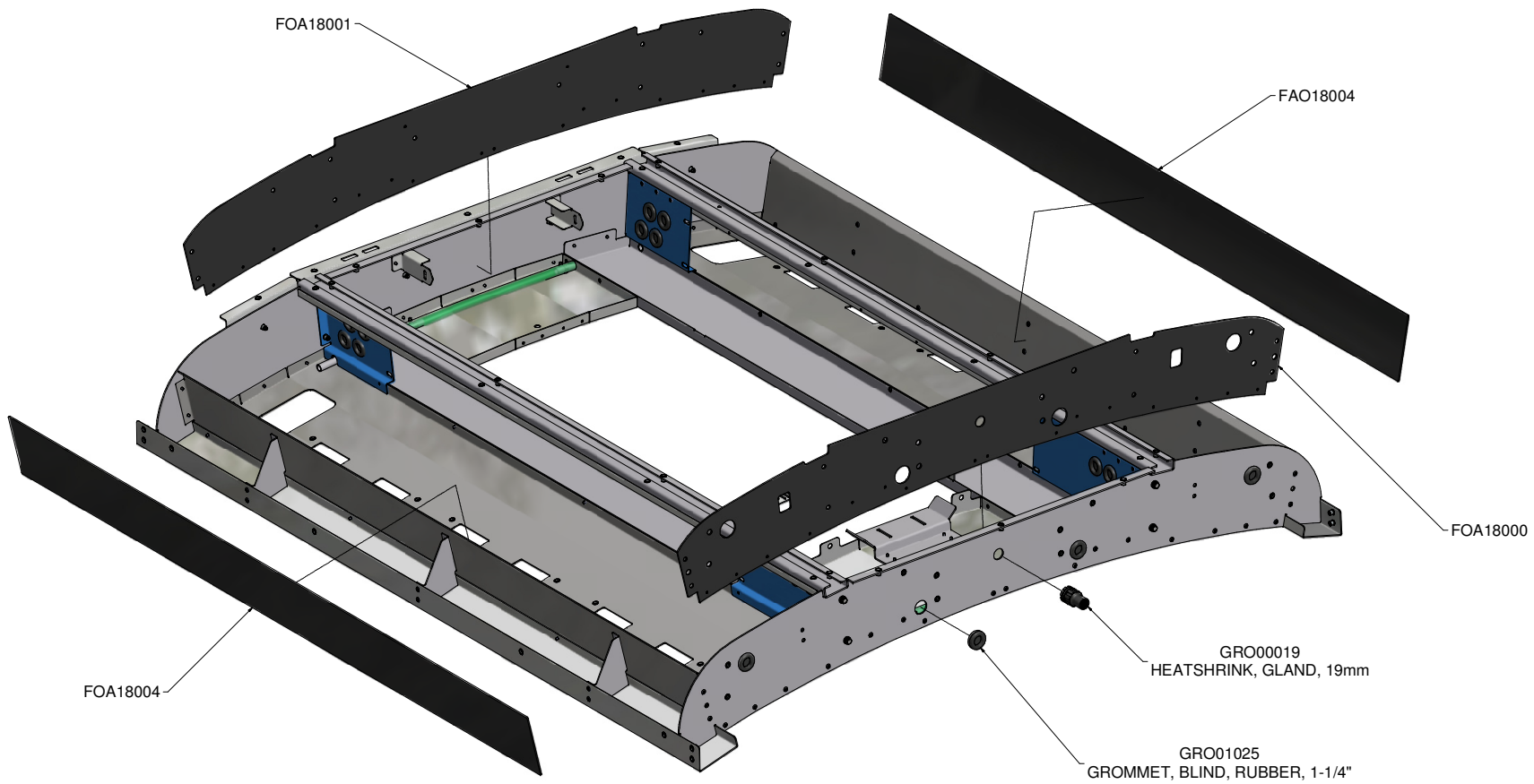

				DRAWN Kalin		3/17/2016		TRANSARCTIC INC.	
				CHECKED James Stewart		3/17/2016			
				RELEASED TO PRODUCTION 3/17/2016		REV CA		TITLE	
REV	ECN	DESCRIPTION	DATE	BY	APPROVED	3/17/2016		EVAPORATOR BASE, KRT18030	
				MFG James Stewart		3/17/2016		DWG NO	
				APPROVED		3/17/2016		KRT18030 BASE	
				DATE Dale Mason		3/17/2016		REV	
				THIRD ANGLE PROJECTION		DRAWING UNIT OF MEASURE		SHEET 1 OF 1	
				UNSPECIFIED TOLERANCES: ALL DIMS		SCALE 1:5		0	
				DIMENSIONAL PRACTICE: AS SHOWN		MM (INCH)			
				FRACTIONAL: 1/32"		2			
				DECIMAL: 0.01					

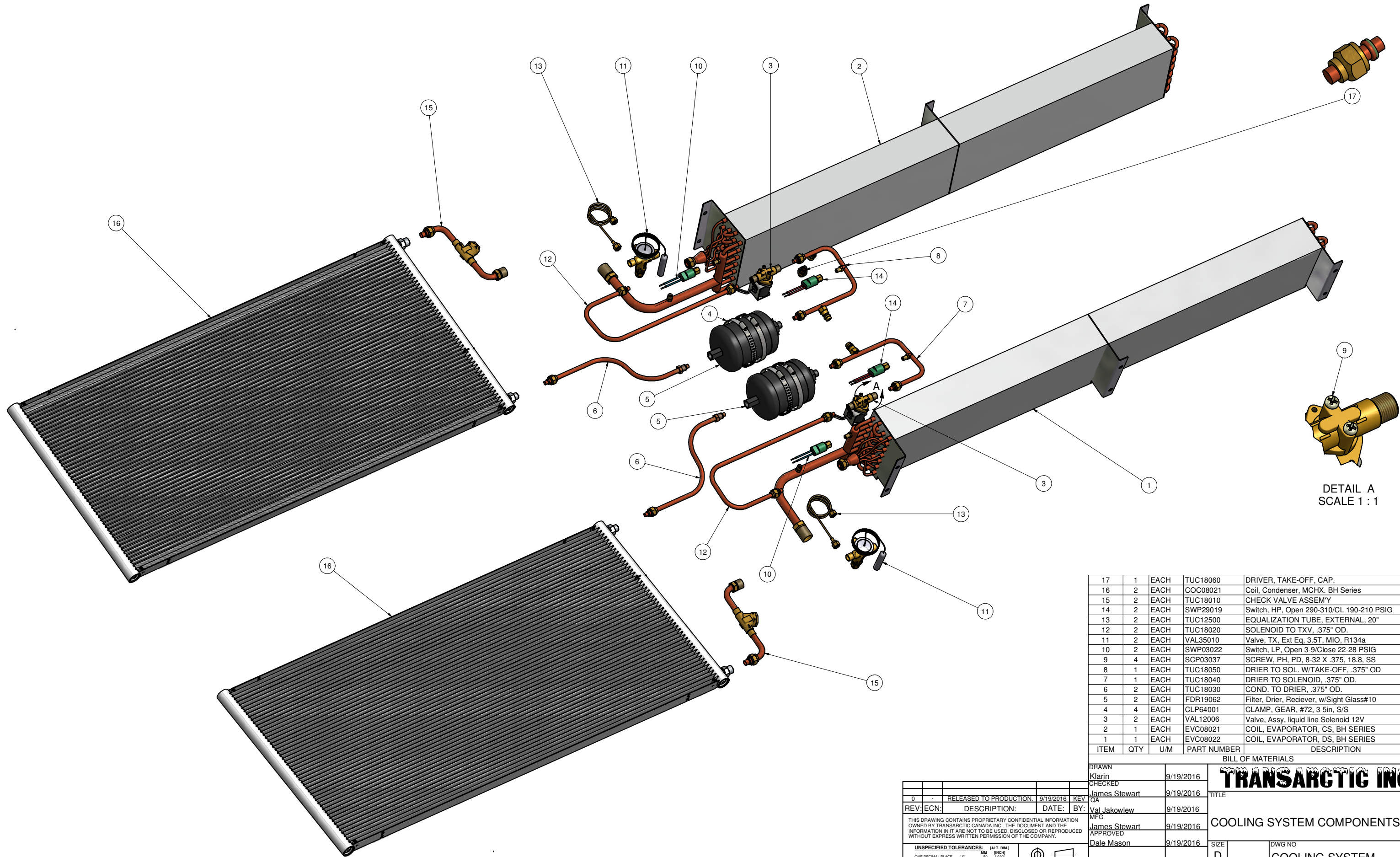

DETAIL A
SCALE 1 : 1

ITEM	QTY	U/M	PART NUMBER	DESCRIPTION
17	1	EACH	TUC18060	DRIVER, TAKE-OFF, CAP.
16	2	EACH	COC08021	Coil, Condenser, MCHX. BH Series
15	2	EACH	TUC18010	CHECK VALVE ASSEM'Y
14	2	EACH	SWP29019	Switch, HP, Open 290-310/CL 190-210 PSIG
13	2	EACH	TUC12500	EQUALIZATION TUBE, EXTERNAL, 20"
12	2	EACH	TUC18020	SOLENOID TO TXV, .375" OD.
11	2	EACH	VAL35010	Valve, TX, Ext Eq, 3.5T, MIO, R134a
10	2	EACH	SWP03022	Switch, LP, Open 3-9/Close 22-28 PSIG
9	4	EACH	SCP03037	SCREW, PH, PD, 8-32 X .375, 18.8, SS
8	1	EACH	TUC18050	DRIER TO SOL. W/TAKE-OFF, .375" OD
7	1	EACH	TUC18040	DRIER TO SOLENOID, .375" OD.
6	2	EACH	TUC18030	COND. TO DRIER, .375" OD.
5	2	EACH	FDR19062	Filter, Drier, Receiver, w/Sight Glass#10
4	4	EACH	CLP64001	CLAMP, GEAR, #72, 3-5in, S/S
3	2	EACH	VAL12006	Valve, Assy, liquid line Solenoid 12V
2	1	EACH	EVC08021	COIL, EVAPORATOR, CS, BH SERIES
1	1	EACH	EVC08022	COIL, EVAPORATOR, DS, BH SERIES

BILL OF MATERIALS
TRANSARCTIC INC.

0	RELEASED TO PRODUCTION.	9/19/2016	KEV
REV	DESCRIPTION:	DATE:	BY:
			Val Jakowlew
			James Stewart
			Dale Mason

UNSPECIFIED TOLERANCES: (ALT. DIM)
 ONE DECIMAL PLACE (.X) .50 (1/20)
 TWO DECIMAL PLACE (.XX) .25 (1/16)
 THREE DECIMAL PLACE (.XXX) .10 (1/16)
 FRACTIONAL: w/1/32" ANGULAR: w/30°

DRAWN	Klarin	9/19/2016	TITLE	
CHECKED	James Stewart	9/19/2016	COOLING SYSTEM COMPONENTS	
APPROVED	Dale Mason	9/19/2016	COOLING SYSTEM	REV 0
DRAWING UNIT OF MEASURE:	MM [INCH]	SCALE	1 : 4	SHEET 1 OF 1

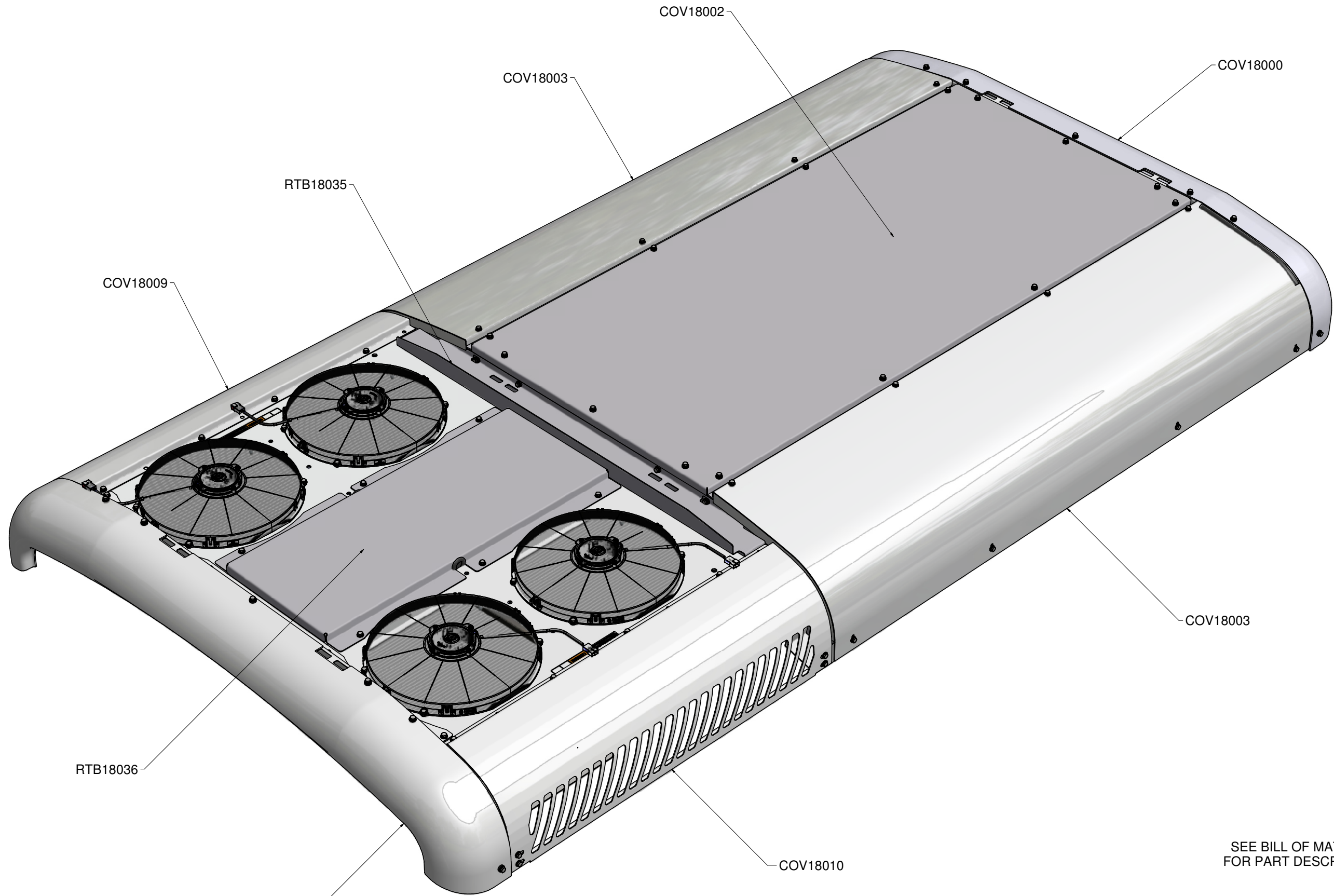

SEE BILL OF MATERIALS
FOR PART DESCRIPTIONS.

DRAWN		Klarin	3/8/2016	TRANSARCTIC INC.	
CHECKED		James Stewart	3/8/2016		
REV	ECN	DESCRIPTION	DATE	BY	TITLE
0		RELEASED TO PRODUCTION	3/17/2016	DA	
				Val Jakowlew	
				James Stewart	KRT18030 COVERS
				Dale Mason	
UNSPECIFIED TOLERANCES:		(ALL DIM)			DWG NO
ONE DECIMAL PLACE	±0.1	(INCH)			KRT18030
TWO DECIMAL PLACE	±0.05	(INCH)			REV
THREE DECIMAL PLACE	±0.01	(INCH)			0
FRACTIONAL ±1/32"		(INCH)			
THIRD ANGLE PROJECTION					DRAWING UNIT OF MEASURE
					MM (INCH)
					SCALE
					1:10
					SHEET 1 OF 1

1

4

3

5

2

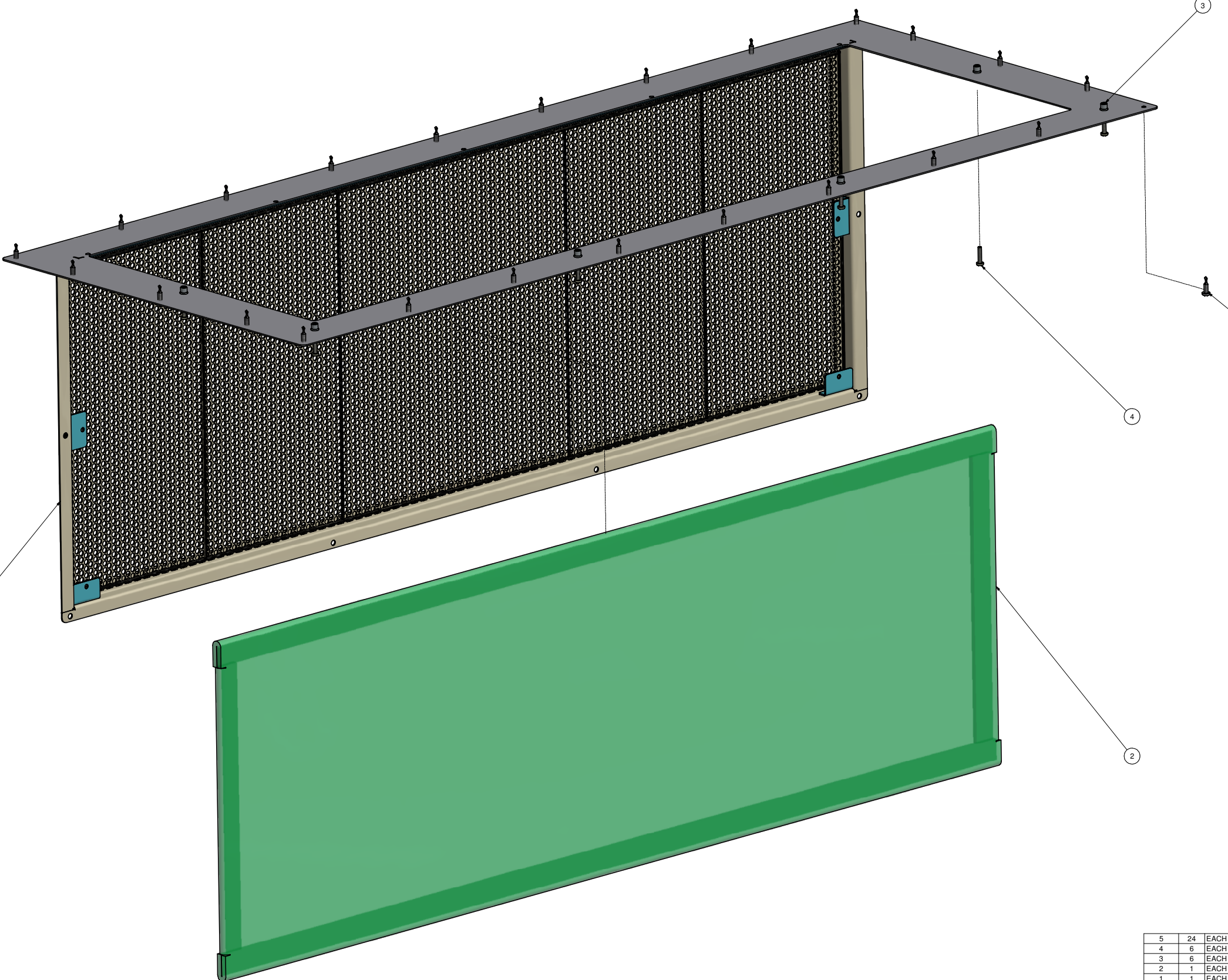

ITEM	QTY	U/M	PART NUMBER	DESCRIPTION
5	24	EACH	SCP03075	SCREW, PH, SDT, #10-16 x .75, ST, PLT
4	6	EACH	SCP03079	SCREW, PH, SDT, 8-32 X .75, 18.8, SS
3	6	EACH	NTS02801	NUT, RIV, 8-32 UNF
2	1	EACH	FIL18000	FILTER, 16" x 48", POLYWIRES, P604, WASHABLE.
1	1	EACH	RTB18027	BKT, AIR INTAKE, WELDMT

DRAWN		9/20/2016		TRANSARCTIC INC.	
CHECKED		9/20/2016			
RELEASED TO PRODUCTION		9/20/2016		TITLE	
REV	ECN	DESCRIPTION	DATE	BY	
			9/20/2016	Val Jakowlew	
APPROVED		9/20/2016		KIT, AIR INTAKE, FILTER	
DALE MASON		9/20/2016			
UNSPECIFIED TOLERANCES:		[Symbol]		DWG NO	
ONE DECIMAL PLACE .1 (INCH)		.1 (MM)		KAF18050	
TWO DECIMAL PLACE .05 (INCH)		.05 (MM)		REV	
THREE DECIMAL PLACE .01 (INCH)		.01 (MM)		0	
FRACTIONAL 1/32" ANGULAR 1/2°		ANGULAR 1/2°		SCALE	
THIRD ANGLE PROJECTION		DRAWING UNIT OF MEASURE		SHEET 1 OF 1	
		MM (INCH)		1 : 2	

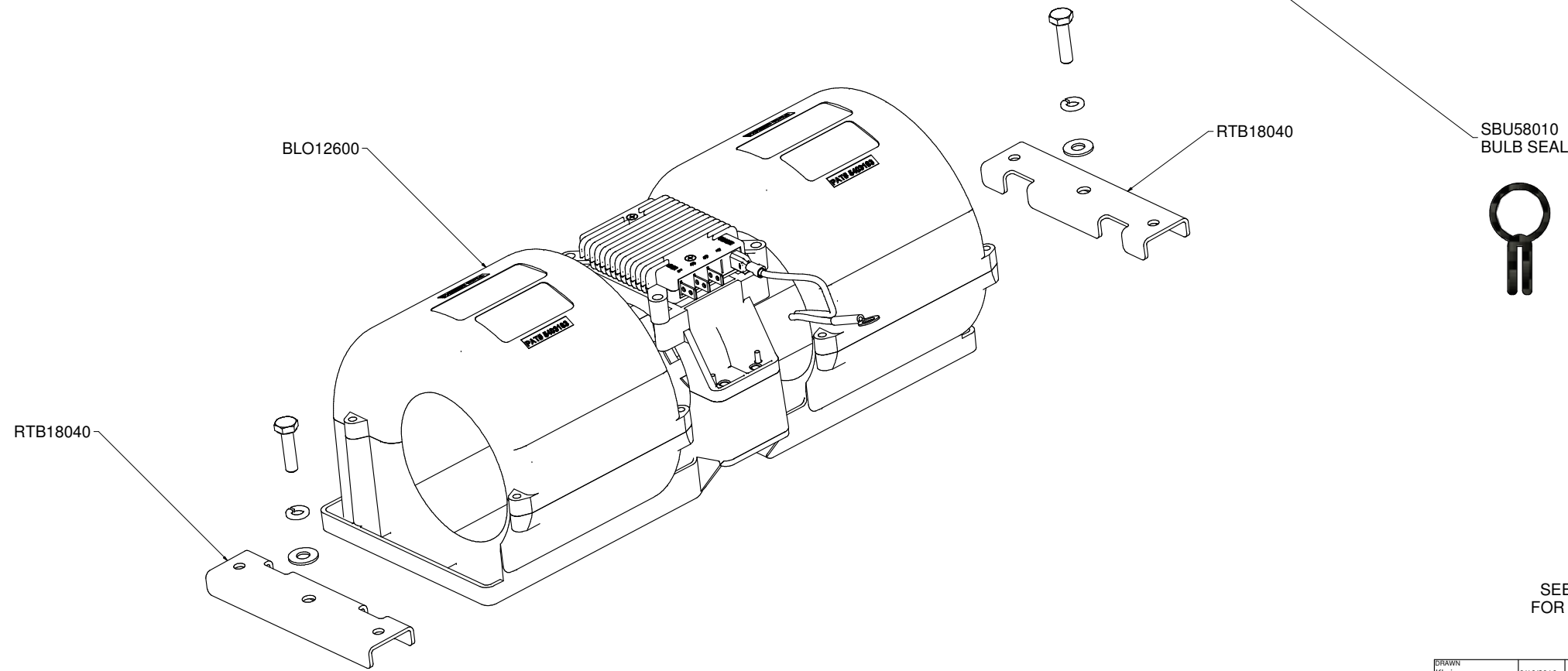
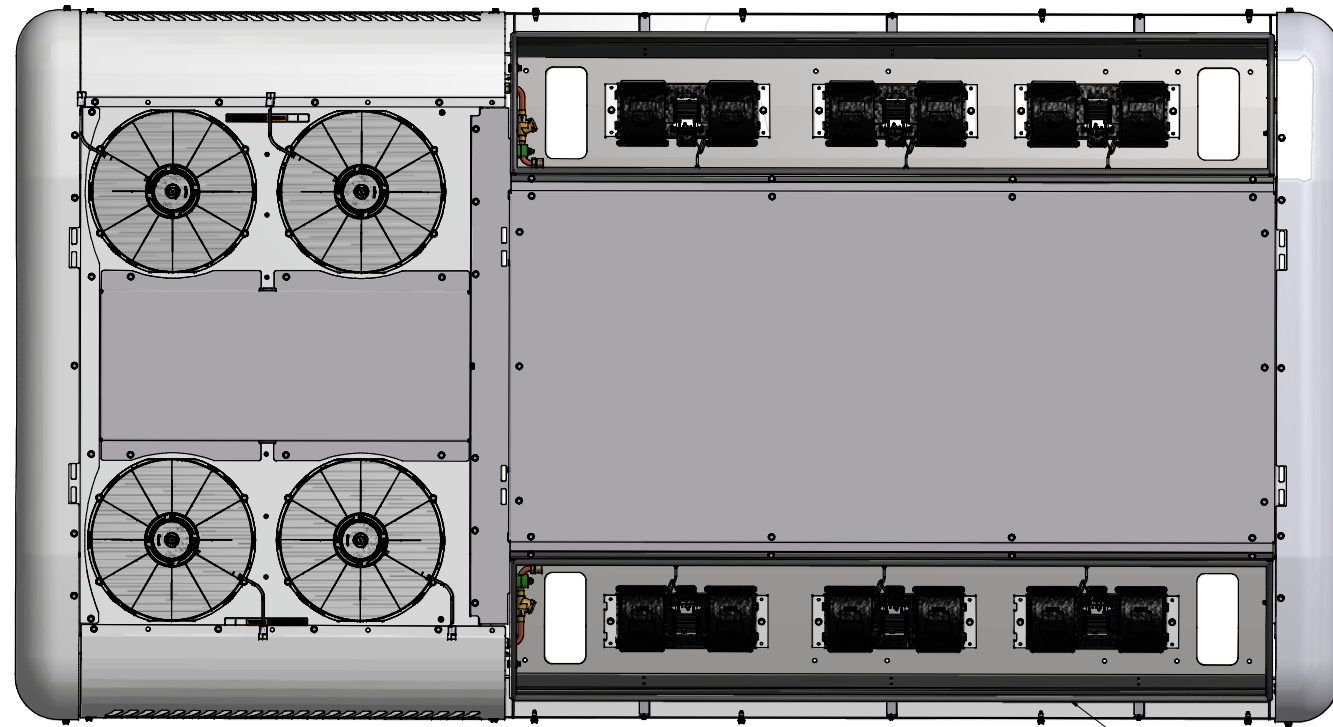

SEE BILL OF MATERIALS
FOR PART DESCRIPTIONS.

DRAWN		Klein	9/16/2016	TRANSARCTIC INC.	
CHECKED		James Stewart	9/16/2016		
REV	ECN	DESCRIPTION	DATE	BY	TITLE
3		RELEASED TO PRODUCTION	9/16/2016	JA	EVAPORATOR BLOWERS
				Val Jakowlew	
				James Stewart	
				Date Mason	
UNSPECIFIED TOLERANCES:		ALL DIM		SIZE	DWG NO
1st DECIMAL PLACE	±0.10	2nd DECIMAL PLACE	±0.05	E	KRT18030-T3
3rd DECIMAL PLACE	±0.02	4th DECIMAL PLACE	±0.01	SCALE	REV
FUNCTIONAL DIM	±0.10	ASSEMBLY	±0.10	1:4	0
THIRD ANGLE PROJECTION		DRAWING UNIT OF MEASURE: MM (INCH)		SHEET 1 OF 1	

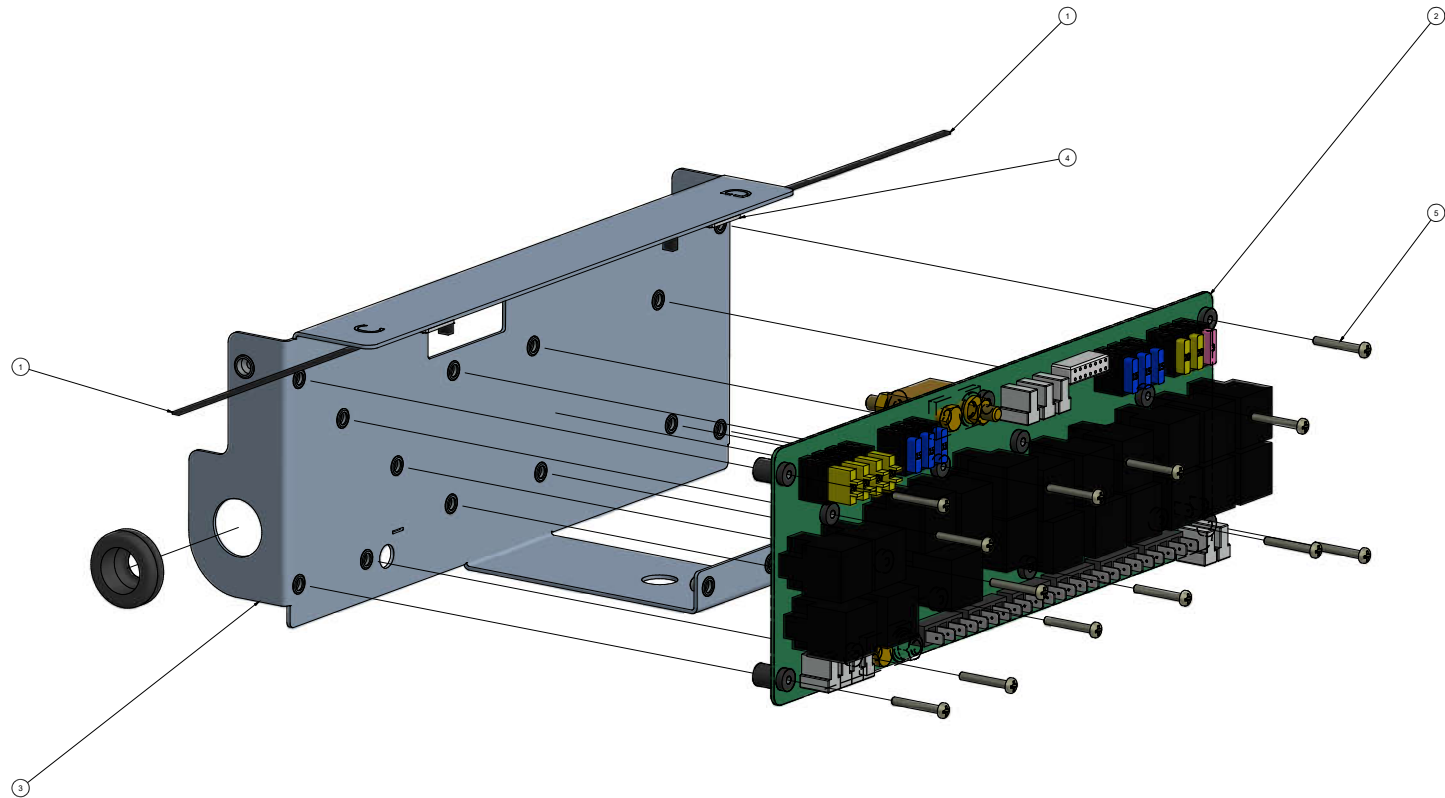

SUB ASSEMBLY

ITEM	QTY	U/M	PART NUMBER	DESCRIPTION
5	13	EACH	SCP03081	SCREW, PH, PD, 8-32 X 1.25, ST, PLT
4	2	EACH	SAH21040	CABLE TIE MOUNT, SELF AD, 1"x1", SQ
3	1	EACH	RTB18071	BKT, ASSEMBY, RELAY PANEL BASE
2	1	EACH	EPH04619	PANEL ASSY, RELAY PANEL, COALS EVAP
1	2	EACH	Z1046	CABLE TIE, 14", UV RESISTANT, BLACK

DRAWN				DATE			
Klarin				3/17/2016			
RELEASED TO PRODUCTION				DATE			
James Stewart				3/17/2016			
DATE				DATE			
Val Jalkovskiy				3/17/2016			
DATE				DATE			
James Stewart				3/17/2016			
DATE				DATE			
Dale Mason				3/17/2016			
DATE				DATE			

REV		DESCRIPTION	DATE	BY
1				
2				
3				
4				
5				

BILL OF MATERIALS		TITLE	
ASSEMBLY, RELAY PANEL.	RTB18047	DATE	3/17/2016
SCALE	1:1	SHEET	1 OF 1

TRANSARCTIC INC.



THIRD ANGLE PROJECTION



TRANSARCTIC

ELECTRONIC CONTROLLER FOR AIR CONDITIONING SYSTEM

GL-P0HTT001 – THERMOSTAT

**April, 2018
Revision 03E
Software Version 1.5**

SUMMARY

1) INTRODUCTION	3
2) SYSTEM OPERATION	4
2.1) Control Panel	4
2.2) Power / Stand by	4
2.2.1) <i>Turning ON the panel in “Automatic Mode”</i>	4
2.2.2) <i>Turning ON the panel in “Manual Ventilation”</i>	4
2.3) Numerical Display	4
2.4) Internal Temperature Sensor	5
2.5) Setpoint	5
2.6) Manual Ventilation Mode	5
2.7) Automatic Mode	6
2.7.1) <i>Automatic Ventilation</i>	6
2.7.2) <i>Cooling</i>	6
2.8) Gas Charge	7
3) SYSTEM PARAMETER	7
4) INPUTS AND OUTPUTS VISUALIZATIONS	8
5) TEST MODE	9
6) HOURMETERS	10
7) FAILURES	11
8) PROTECTIONS	11
9) OPERABILITY	11
10) REVISION RECORD	12

1) INTRODUCTION

The electronic controller of air conditioning system, **GL-P0HTT001** is a microprocessed device, developed to control and supervise air conditioning systems for buses. It acts on ventilators, condensers and compressors to get the temperature level desired inside the vehicle. It receives information of temperature and system pressure.



2) SYSTEM OPERATION

2.1) Control Panel





The control panel installed in the driver's panel has a main CPU composed by an operational programming keyboard of the air conditioning system and of a numerical display for the parameters visualization, operational status and temperature.

2.2) Power / Stand by





When supplying the panel in 12/24V_{DC}, the display will indicate software version and after the display will turn off, indicating that the panel is in "stand by" mode. To exit of stand by mode you should follow the item 2.2.1 or 2.2.2.

2.2.1) Turning ON the panel in "Automatic Mode"

To turn ON the panel in automatic mode, press , it will show the temperature on the display. The control will be done according to the item 2.7.

To turn OFF the panel you should press  for 3s.

2.2.2) Turning ON the panel in "Manual Ventilation"

To turn ON the panel in manual ventilation mode, press  (vent up) or , it will show **u0** on the display (ventilation OFF) and to change the speed, press  (vent_up) or  (vent_down) as the item 2.6.

To turn OFF the panel you should press  for 3s.

2.3) Numerical Display

In automatic mode, besides show the programmed setpoint, the display will show the internal temperature to the driver, as well as system failures, access to the parameters and programmed speed.

In manual ventilation mode, the display will indicate the programmed speed, internal temperature, setpoint and system failure.

2.4) Internal Temperature Sensor

When the parameter **SL** will be equal to **1**, the display will show the setpoint value. If the parameter **SL** will be **0**, the display will show the internal temperature. With **SL** equal to **1**, to visualize the temperature, press **1**, and 2 dots will keep blinking alternately on the display, what indicate that the display will keep showing the temperature and not the setpoint. Posteriorly the panel will return indicating the setpoint and the dots will stop blinking.

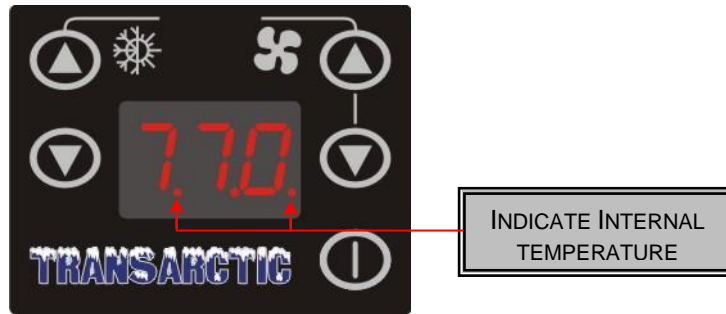

2.5) Setpoint

Setpoint is the temperature desired inside the vehicle. To regulate it, press **▲** (up) or **▼** (down). The setpoint temperature will show blinking on the display, so press again one of the buttons until you reach the temperature desired.



2.6) Manual Ventilation Mode

After enter in manual ventilation mode (as the item **2.2.2**) the display will indicate **u0** (ventilation OFF). To change the speeds, you should press the buttons **▲** (vent_up) or **▼** (vent_down) as the table below:

Visualization on the panel	Speed
u0	Ventilation OFF
u1	Ventilation Low Speed
u2	Ventilation Medium Speed
u3	Ventilation High Speed

2.7) Automatic Mode

After enter in automatic mode (according to the item 2.2.1), the control will be done through the setpoint and parameters **P1**, **PA** e **dC**, as described on items 2.7.1 and 2.7.2:

2.7.1) Automatic Ventilation

When entered in automatic mode, the panel will activate an automatic ventilation according to the setpoint and the parameters **P1** and **PA**, as shows the graph below:

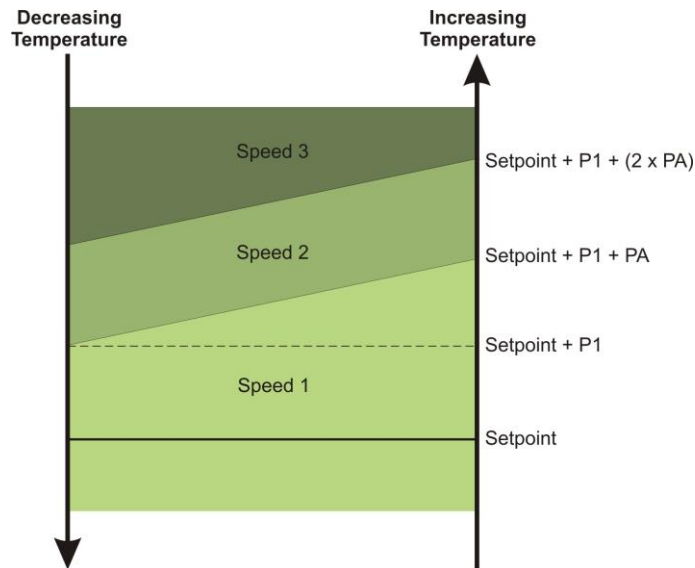

2.7.2) Cooling

When entered in automatic mode, the cooling will be controlled by the setpoint and parameter **dC**, as shows the graph below:

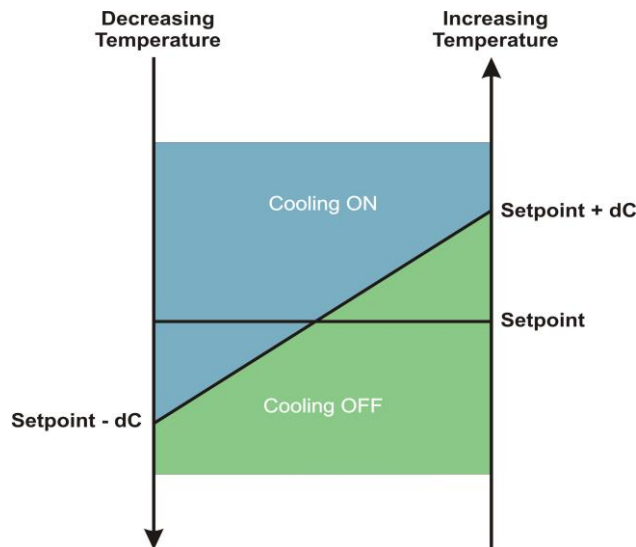



The compressor **2** will be turn ON 5s after the compressor **1** turn ON. The condenser just turn off if an failure occurred on both pressure switches, or by automatic control. There is a hysteresis of 30s when the condenser restarts.











2.8) Gas Charge

It allows to turn ON the air conditioning independent of the temperature sensor. Turn ON the condenser and the ventilation in low speed, respecting the pressure switch input. It has by function the gas charge and could only be activated in test mode by the system.

3) SYSTEM PARAMETER

- To access the parameters, press simultaneously the buttons  (down) and  (vent_down) for 3s;



- 3 lines will show on the display, which the password **053** should be entered on the display;
- To enter the password, use  (up) to increase and  (down) to decrease. To change the digit, press , after digit the password **053**, press again  to enter on the parameters;
- The first parameter is **P0**, to navigate on the parameters, press  (up) or  (down);
- To visualize the parameter value, press .
- To change the value, press  (up) or  (down) and confirm again the value, pressing .
- To exit, press .



Adjustable Parameters

Parameter	Function	Def	Min	Max
P0	Off-set sensor temperature	0°C	-5°C	+5°C







P1	Temperature above the setpoint to change blowers speed	1°C	1°C	5°C
PA	Hysteresis temperature to change blowers' speed	1°C	1°C	5°C
dC	Hysteresis temperature to activate the cooling	1°C	1°C	4°C
SL	Standard visualization on display (0 = temperature; 1 = setpoint)	1	0	1
Pr	Auto Start Up (0 = disable; 1 = enable)	0	0	1
BL	Block de setpoint (0 = disable; 1 = enable)	0	0	1
Lt	Minimum value of setpoint	15°C	-40°C	35°C
Ht	Maximum value of setpoint	32°C	-40°C	35°C
CF	Temperature scale (0 = Celsius; 1 = Fahrenheit)	1	0	1

4) INPUTS AND OUTPUTS VISUALIZATIONS

This panel allows the visualization of inputs and outputs in order to know if they are activated or deactivated.

- To access this mode, press simultaneously the buttons  (down) and  (vent_down) for 3s;





- 3 lines will show on the display which the password **011** should be entered;
- To enter the password, use  (up) to increase and  (down) to decrease. To change the digit, press , after digit the password **011**, press again  to enter in visualizations;
- The first visualization is **SP1**. To navigate through the visualizations, press  (up) or  (down);
- To exit, press  (vent_up).
 - **Led ON** = input with signal or activated output;
 - **Led blinking** = input without signal or output OFF;







Indication	Description
SP1	Ventilation - Low Speed
SP2	Ventilation - Medium Speed
SP3	Ventilation - High Speed
CL1	Compressor 1
CL2	Compressor 2
CdS	Condenser
Pr1	Pressure Switch 1
Pr2	Pressure Switch 2

5) TEST MODE

Use this test mode to test inputs and outputs, which is possible to change its states.

- To access this mode, press simultaneously the buttons  (down) and  (vent_down) for 3s;





- 3 lines will show on the display, which the password **086** should be entered;
- To enter the password, use  (up) to increase  and (down) to decrease. To change the digit, press , after form the password **086**, press again  to enter in visualization;
- The first test is **PS1**, to navigate through the visualizations, press  (up) or  (down);
- To exit, press  (vent_up).
 - **Led ON** = input with signal or output activated;
 - **Led blinking** = input without signal and output OFF;

Indication	Description
PS1	Pressure Switch 1
PS2	Pressure Switch 2
SP1	Ventilation - Low Speed





SP2	Ventilation - Medium Speed
SP3	Ventilation - High Speed
CG1	Gas Charge 1 (Condenser + Compressor 1+ Ventilation – High Speed)
CG2	Gas Charge 2 (Condenser + Compressor 2+ Ventilation – High Speed)
CdS	Condenser
dY	Display

6) HOURMETERS

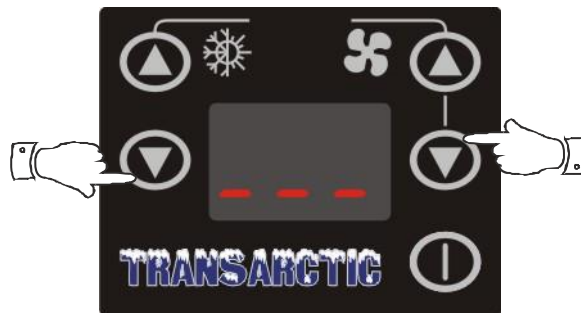
This panel has four hourmeters for visualization:

- Compressor 1 or 2 hourmeter;
- Unit total hourmeter;
- Compressor 1 hourmeter;
- Compressor 2 hourmeter.
- To access this mode, press simultaneously the buttons  (down) and  (vent_down) for 3s;



- After the display show the 3 lines on the display, put the password **046** (according descrcbd below);
- To enter the password, use  (up) to increase  and (down) to decrease. To change the digit, press , after form the password **046**, press again  to enter in visualization;
- The first visualization is the compressor hourmeter, as shown in the following table:

Indication	Description
Cxx	Compressors Hourmeter (compressor 1 or Compressor 2)
Uxx	Unit Total Hourmeter
Axx	Compressor 1 Hourmeter
bx	Compressor 2 Hourmeter

Note: the visualization format will be given as follows: for example **C18** and after **362**, it will correspond to 18362h.

- To exit, press  (vent_up).

7) FAILURES

Failure	Description	Action
FP1	Pressure Switch Failure 1	When occur a pressure switch failure (1 or 2), the corresponding compressor output will be turned off immediately and after 3 minutes the display will be indicate the respective. After the failure fixed the corresponding compressor output will turn on in 1 minute.
FP2	Pressure Switch Failure 2	
F1	Failure of Internal Temperature Sensor	Shows only the failure code

Obs¹: If it will be in **CG** mode (gas charge) the display will show **CG** changing with **FP**, the condenser will be OFF, returning to be ON only after the failure, i.e., after 30 seconds of the re-establishment, the condenser will be OFF.

Obs²: If it happens 10 or more pressure switch failures in 1 hour, the display will show code **FS1** (for pressure switch 1) and **FS2** (for pressure switch 2).

8) PROTECTIONS

- The control panel has protected outputs against short circuit which actuates in a thermal circuit.
- The maximum output current per pin is 180mA.

9) OPERABILITY

- This controller should operate in a maximum temperature range from -10°C to 70°C.
- This controller should operate in ideal conditions of humidity and temperature;
- This controller operates with nominal voltage of 12V_{DC} and 24V_{DC}.
- In a continuous basis, it should operate with voltage 10 V_{DC} to 29V_{DC}, with integrity of all functions.
- The electronic system should support 32V_{DC}, during 5 minutes, without any permanent damages.
- The circuit control should support -12V_{DC} / -24V_{DC} (polarity reversion) indefinitely, without any damage.

10) REVISION RECORD

Revision	Date	Author	Description
A	02/27/2014	FK	Original file.
02	05/11/2017	FK	Changed the description of item 2.2; Changed the description of item 2.7.2; Changed default of parameters SL and Pr ; Included item 6 - Hourmeters; Changed the description of item 7.
03	04/03/2018	FK	Included separate hourmeter for each compressor.

COMPANY

Globus is a company that develops, manufactures, and markets Electronic Control equipment.

It has two divisions:

- Automotive: Customized OEM Products.
- Automation Systems: equipment for the automation of refrigeration and air conditioning systems.

MISSION

Provide electro-electronic solutions, adding value to our customers' products and services.

AIM:

To be a world reference in technological solutions.

QUALITY

Ever since December 2000 the company has been ISO 9001 certified for the process of DEVELOPMENT, INDUSTRIALIZATION, AND TECHNICAL ASSISTANCE OF ELECTRONIC PRODUCTS FOR AUTOMOTIVE APPLICATION AND AUTOMATION SYSTEMS.

POLICY QUALITY

To improve our products and processes on a continuous basis, aiming at the satisfaction of Customers, Coworkers, and Shareholders.

OBJECTIVES OF QUALITY:

Improvement of product quality

New Technologies

Customer Satisfaction

Coworkers' Satisfaction

RESEARCH AND DEVELOPMENT

Our Engineering Team is ready to analyze, suggest, specify, and implement complete solutions in temperature and humidity control systems. With a highly qualified and experienced technical team, we will identify the best product for your application. Through our know-how we can design equipment within your needs and specifications. Our key features are versatility, flexibility, and quickness in developing new projects and products, allied to a high technology and quality standard. Bring your ideas to our Engineering Team. We will certainly have the solution at the right measure.



WIRE HARNESSES

HAR18101.....	Driver Control
HAR18201.....	Solenoid Loop
HAR18301.....	Evap Blowers
HAR18401.....	Condensers
HAR18501.....	DS Safety Loop
HAR18601.....	CS Safety Loop

See Bill of Materials for full Harness descriptions.

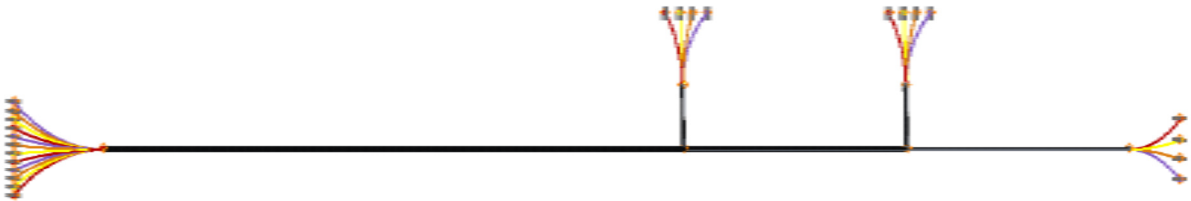

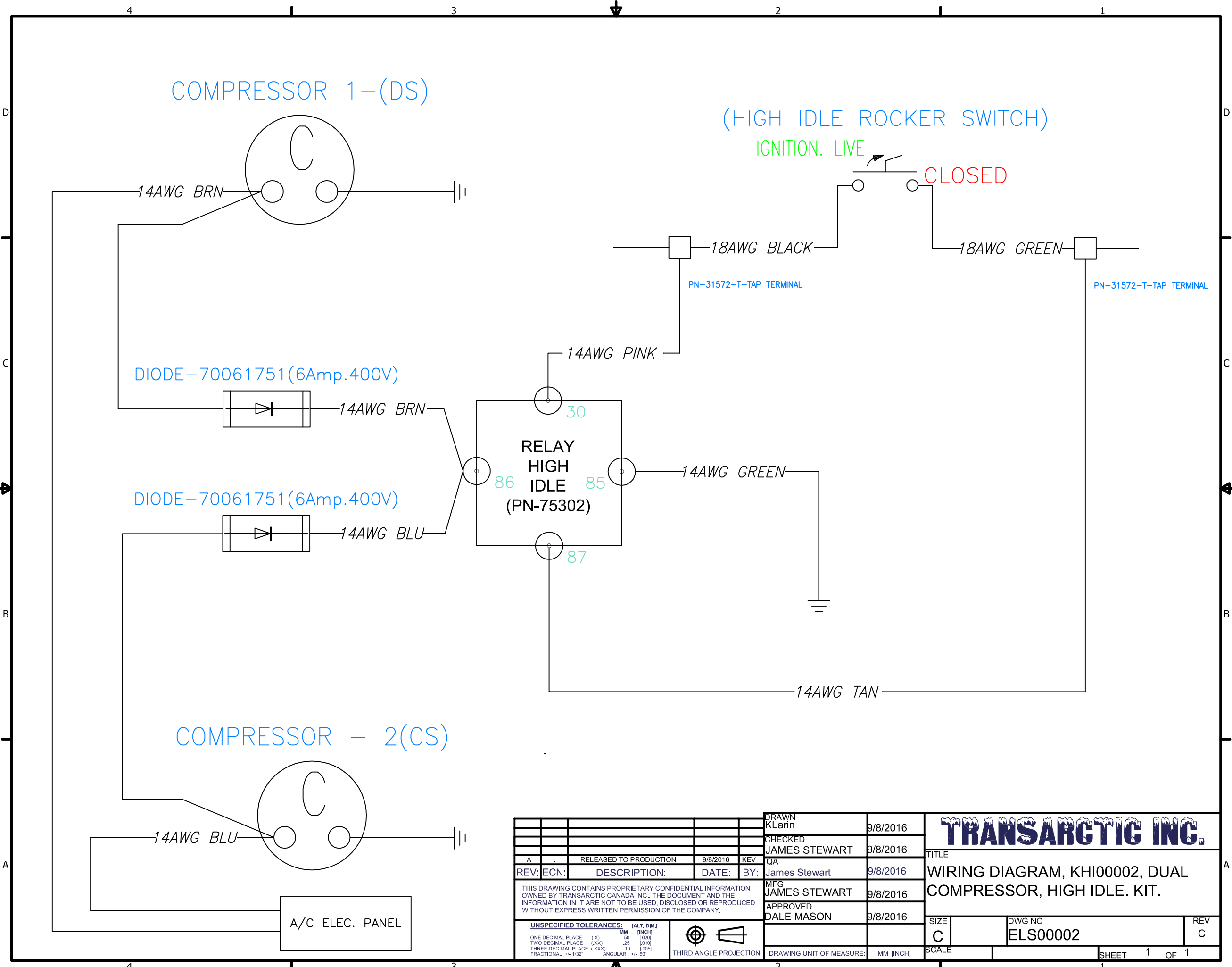

DRAWN KLarin				9/8/2016	TRANSARCTIC INC.															
CHECKED JAMES STEWART				9/8/2016																
REV: ECN: DESCRIPTION: DATE: BY:				QA James Stewart	9/8/2016															
THIS DRAWING CONTAINS PROPRIETARY CONFIDENTIAL INFORMATION OWNED BY TRANSARCTIC CANADA INC.. THE DOCUMENT AND THE INFORMATION IN IT ARE NOT TO BE USED, DISCLOSED OR REPRODUCED WITHOUT EXPRESS WRITTEN PERMISSION OF THE COMPANY.				MFG JAMES STEWART	9/8/2016															
UNSPECIFIED TOLERANCES:				APPROVED DALE MASON	9/8/2016															
<table border="1"> <tr> <th></th> <th>MM</th> <th>[INCH]</th> </tr> <tr> <td>ONE DECIMAL PLACE (X)</td> <td>.50</td> <td>[.020]</td> </tr> <tr> <td>TWO DECIMAL PLACE (XX)</td> <td>.25</td> <td>[.010]</td> </tr> <tr> <td>THREE DECIMAL PLACE (XXX)</td> <td>.10</td> <td>[.005]</td> </tr> <tr> <td>FRACTIONAL +/- 1/32"</td> <td></td> <td>ANGULAR +/- .50°</td> </tr> </table>					MM	[INCH]	ONE DECIMAL PLACE (X)	.50	[.020]	TWO DECIMAL PLACE (XX)	.25	[.010]	THREE DECIMAL PLACE (XXX)	.10	[.005]	FRACTIONAL +/- 1/32"		ANGULAR +/- .50°		
	MM	[INCH]																		
ONE DECIMAL PLACE (X)	.50	[.020]																		
TWO DECIMAL PLACE (XX)	.25	[.010]																		
THREE DECIMAL PLACE (XXX)	.10	[.005]																		
FRACTIONAL +/- 1/32"		ANGULAR +/- .50°																		
DRAWING UNIT OF MEASURE: MM [INCH]				SIZE C	DWG NO ELS00002															
				SCALE	REV C															
				SHEET 1 OF 1																

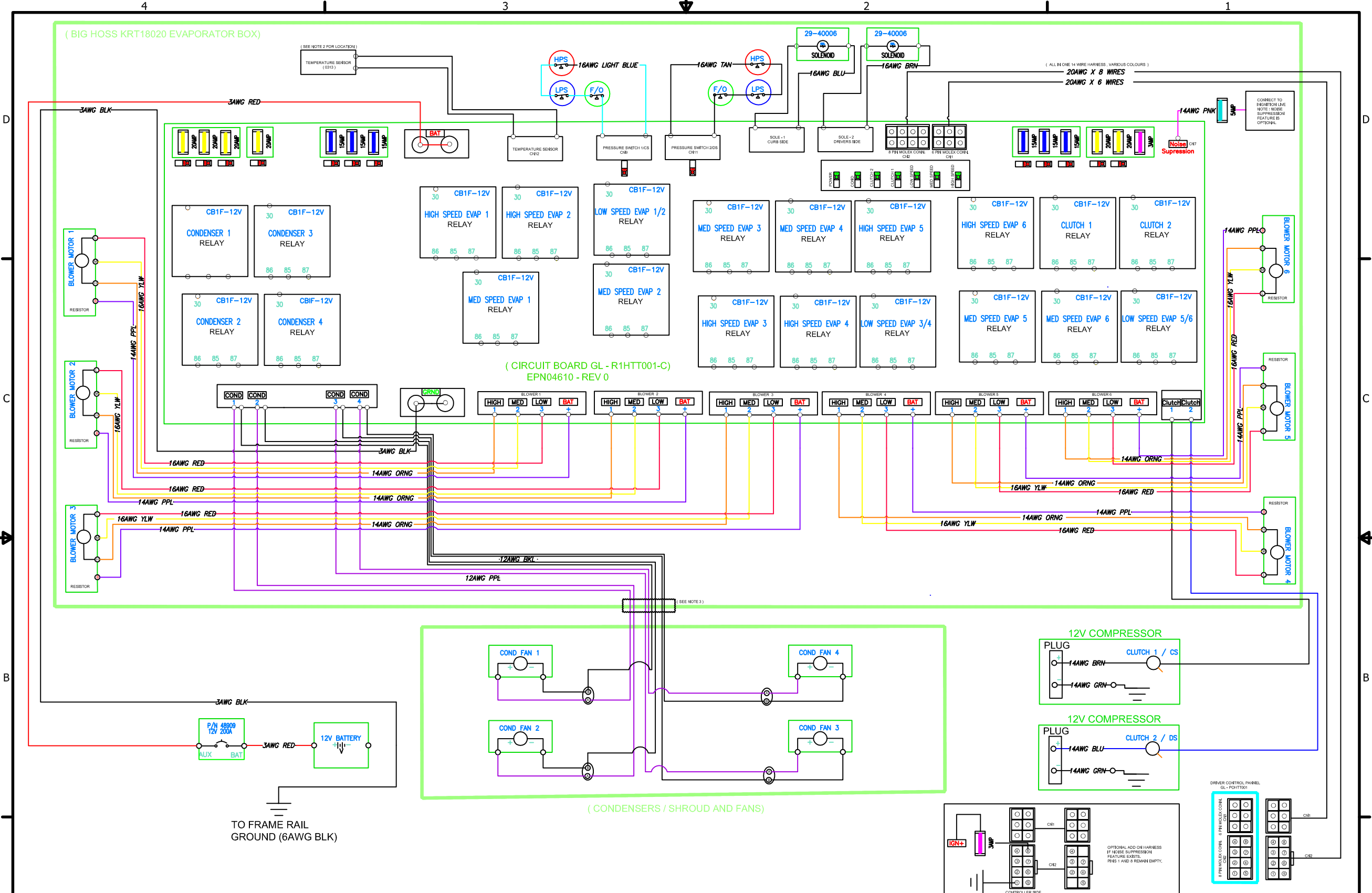

- NOTES:
- 1) USE 2 PLUG BLACK WEATHER PACK CONNECTORS ON CONDENSER FANS.
 - 2) TEMPERATURE SENSOR RUNS TO CENTER OF EVAP. INTAKE WHERE IT HANGS IN AIR FLOW.
 - 3) 8 WIRE CONDENSER HARNESS RUNS INTO PASSTHRU HEAT SHRINK GROMMET INTO EVAP. BOX

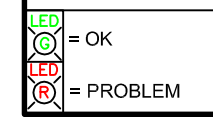

REV: ECN:	DESCRIPTION:	DATE:	BY:
C	UPDATE WIRING FOR NEW BOARD	7/12/2016	KEV
B	COND. RELAYS FROM 20 TO 30AMP	2/04/2015	KEV
A	RELEASED TO PROTOTYPE	7/09/2014	KEV
THIS DRAWING CONTAINS PROPRIETARY CONFIDENTIAL INFORMATION OWNED BY TRANSARCTIC CANADA INC.. THE DOCUMENT AND THE INFORMATION IN IT ARE NOT TO BE USED, DISCLOSED OR REPRODUCED WITHOUT EXPRESS WRITTEN PERMISSION OF THE COMPANY.			
UNSPECIFIED TOLERANCES: [ALT. DIM.]			
ONE DECIMAL PLACE (X)	MM [INCH]	50 [2.00]	
TWO DECIMAL PLACE (XX)	MM [INCH]	.25 [.010]	
THREE DECIMAL PLACE (XXX)	MM [INCH]	.10 [.005]	
FRACTIONAL (+.102)	ANGULAR (+.50)		

DRAWN: K.Larin 7/09/2014

CHECKED: JAMES STEWART 7/09/2014

QA: James Stewart 7/09/2014

MFG: JAMES STEWART 7/09/2014

APPROVED: DALE MASON 7/09/2014

TRANSARCTIC INC.

TITLE: WIRING DIAGRAM, KRT18001

SIZE: C DWG NO: ELS18001 REV: C

SCALE: SHEET 1 OF 1

Bill of Materials Listing

10/4/2022
Page 1 of 3

TransArctic Canada Inc.

Product Number	Date	Description	Uof M	Weight	Yield		
Line	Qty	Component Prod#	Rev#	Description	Location	Unit	
RTC34030	03/13/18	0	0	Kit, Rooftop, BB, DL, 12V, Electronic		87005.72	0
10	40	21046		Cable Tie, 14", UV Resistant, Black			
20	17	21371		Cable Tie Mounting Base&Fir Tree		each	
30	6	BLO12600	0	Blower, Dual Scroll, 3 SP, 12V		each	
35	1	BMZ01066	0	Bkt, Bezel, Drivers Control		each	
50	6.00	CLP20016		Clamp, "P" type, #16, 1/2"w, 1", PC		Each	
80	2	CLS00500		1/2, Stauff Clamp, Polypropylene		each	
90	2	COC08021	0	Coil, Condenser, MCHX, BH Series		each	
100	1	COV18000	0	Cover, Fiberglass, T3 End Cap		each	
110	1	COV18001	0	Cover, Fiberglass, T3 Condenser Inlet		each	
120	1	COV18002	0	Bkt, Main Evap Coil Cover, AL		each	
130	2	COV18003	2	Cover, T3 Evaporator Box, AL		each	
140	1	COV18009	1	Cover, CS,T3 Condenser Side Inlet, AL		each	
150	1	COV18010	1	Cover, DS,T3 Condenser Side Inlet, AL		each	
160	1	DPA18030	0	BB, Drain Pan, Sub Ass'y		each	
200	1	FOA18000	1	Foam, AS, T3 Front Flange		each	
210	1	FOA18001	1	Foam, AS, T3 Rear Flange		each	
220	1	FOA18002	A	Foam, AS, Evap, Coil Cover		each	
230	2	FOA18003	A	Foam, AS, Evap, Blower Box, Cover		each	
240	2	FOA18004	B	Foam, Anti-Sweat, Blower Box Side		each	
250	31.00	FOA18008	A	Gasket, Evap, Neoprene, 1/2" x 1/16"		Feet	
290	8	FOA18012	A	Gasket, Tape, Neoprene, 2" x 1/16"		feet	
310	1	FOA37532	A	Evap, Cover, Rear, Seal, 3/4"x3/8"x32"		each	
315	2	FTS08075		Ftg, Plastic Cap W/Rubber Seal, #8 MIO		each	
320	2	FTS10602	0	Evap, Nut, Pass-Thru,1-1/16"-14-Unf		each	
325	2	FTS12106		Ftg, Plastic Cap W/Rubber Seal, #12 MIO		each	

Bill of Materials Listing

TransArctic Canada Inc.

10/4/2022
Page 2 of 3

Product Number		Date	Description		Uof M	Weight	Yield
Line	Qty	Component Prod#	Rev#	Description	Location	Unit	
330	1	GRO00019		Heatshrink, Gland, 19mm		each	
340	4	GSK18000	0	Gasket, U-Channel, 5/8" x 1-1/4" x 40"		each	
350	1	HAR18101	2	Harness, Drivers Control		each	
360	1	HAR18201	0	Harness, Solenoid Circuit, 1/4" Spade		each	
370	2	HAR18301	0	Harness, 3 Evaporator Blower, 1/4" Spade		each	
380	1	HAR18401	0	Harness, Condenser, WP & 1/4" Spade		each	
390	1	HAR18501	0	DS, Safety Loop, 2 Wire, 16AWG		Each	
400	1	HAR18601	0	CS, Safety Loop, 2 Wire, 16AWG		each	
420	1	JEP18010	1	Sub Kit, Electrical Panel, Roof Top		each	
430	1	KAF18050	3	Kit, Air Intake, Filter.		each	
460	5	ORS20737		O Ring, Seal, 3/8" OD, R-134 #6 Bump		Each	
470	4	ORS20738		O Ring, Seal, 1/2" OD, R-134, #8 Bump		each	
490	6	RTB18014	0	Bkt, Gusset, Evap Box, AL		each	
510	1	RTB18032	3	Bkt, T3 Condenser, CS Inner, AL		each	
520	1	RTB18033	3	Bkt, T3 Condenser, DS Inner, AL		each	
530	1	RTB18035	0	Bkt, Condenser Close Out, Rear, AL		each	
540	12	RTB18040	0	Bkt, Blower, Tie Down, AL.		each	
550	4	RTB18043	0	Bkt, Plate, Suction Fitting, Close out		each	
560	2	RTB18045	0	Bkt, Support, Relay Panel Base, AL			
570	2	COA18030		Condenser, Rooftop, BB, C2, HDX, Ass'y		each	
580	1	RTB18055	0	Bkt, Assem'y, Condenser Main Cover		each	
590	1	RTB18056	0	Bkt, Assem'y, T3 Condenser, CS Outer,		Each	
600	1	RTB18057	0	Bkt, Assem'y, T3 Condenser, DS Outer		each	
610	2	RTB18058	0	Bkt, Assem'y, Condenser Shroud Strut		Each	
620	1	RTB18059	1	Bkt, Assem'y, T3 Evap Front Flange		Each	
630	1	RTB18060	0	Bkt, Assem'y, T3 Evap Rear Flange		each	

Bill of Materials Listing

TransArctic Canada Inc.

Product Number	Date	Description		Uof M	Weight	Yield
Line	Qty	Component Prod#	Rev#	Description	Location	Unit
640	1	RTB18061	0	Bkt, Assem'y, T3 Blower Base, DS		each
650	1	RTB18062	0	Bkt, Assem'y, T3 Blower Base, CS		each
660	2	RTB18063	0	Bkt, Assem'y, Evap, Outer Channel		each
670	1	RTB18064	0	Bkt, Assem'y, Evap Coil CloseOut,Rear DS		each
680	1	RTB18065	0	Bkt, Assem'y, Evap Coil CloseOut,Rear CS		each
690	1	RTB18066	0	Bkt, Assem'y,Evap Coil Close Out,FrontCS		each
700	1	RTB18067	0	Bkt, Assem'y,Evap Coil Close Out,FrontDS		each
710	1	RTB18068	0	Bkt, Assem'y, Front Condenser Inlet		each
720	1	RTB18069	1	Bkt, Assem'y,Evap Cover Support,w/L Eyes		each
730	2	RTB18070	0	Bkt, Assem'y, Evap Rain Channel, Weldm't		each
745	1	RTB18076	0	Bkt, Support, Brace, F-D		each
750	8	SAH21040		Cable Tie Mount, Self AD, 1" x 1" SQ.		each
760	29.50	SBU58010		Trim, 5/8" bulb x 9/16" x 1/8" grip.		feet
830	2	TUC18010	4	Ass'y, Check Valve, .5" OD		Each
880	2	TUC18070	2	Tube, Cond. to Drier, .375" O.D,2" Short		each
910	137	BTS04076		Bolt, Hex, 1/4-28unf, .75", SS		each
920	14	BTS04104		Bolt, Hex, 1/4-28UNF x 1.00, SS		each
930	4	BTS04201		Bolt, Hex, 1/4-28 UNF, 2.00", 18-8, SS		each
950	4	NTM04001		Nut, Hex, 1/4-28unf, 18-8, SS		each
970	102.00	RIV03029		Rivet, Closed End, 3/16" .188-.25, AL/ST		each
975	12	SCP03075		Screw, PH, PD, SDT, #10-16 x .75, ST,Pt		each
980	2	SCP03079		Screw, PH, PD, 8-32 x .75, 18.8, SS		each
1,000	175	WFS04001		Washer, Flat, 1/4", 18-8, SS		each
1,010	56	WFS04075		Washer, Flat, 1/4", .75" O.D, Nylon 6.6		each
1,020	160	WLS04000		Washer, Lock, 1/4", 18-8, SS		each

Bill of Materials Listing

TransArctic Canada Inc.

9/15/2025
Page 1 of 2

Product Number		Date		Description		Typ	Uof M	Weight	Yield
Line	Qty	Component	Prod#	Rev#	Description	Location	Typ	Unit	
DPA18060			8/11/2021	1	BB, Drain Pan, Sub Ass'y		Ma	99.05	0
20	2	BTS05008			Bolt, Hex, Flg, 5mm x 0.8 x 8, Blk		No	each	
30	2	CLP72001			Clamp, Gear, #72, 3" - 5" (76.2/127mm)		No	each	
40	2	CLP20006			Clamp, "P" type, #6, 1/2"w, 3/8", PC		No	each	
50	1	ECA18041			Evap Coil Ass'y, EVC08041		Ma	each	
60	1	ECA18042			Evap Coil Ass'y, EVC08041		Ma	each	
70	2	FDR19062			Filter Drier Reciever, w/SG, #10, Large		Pr	each	
80	2	FOA18601		A	Foam, Anti Spla, 15ppi, 1/2"x2.5"x 60"		Ma	each	
90	2	FOA18602		A	Foam, Anti Spla, 15ppi, 1/2"x7"x 3.5"		Ma	each	
100	2	FOA18603		A	Foam, Anti Spla, 15ppi, 1/2"x7"x 9"		Ma	each	
110	2	FTS04113			1/4" SAE. M Run x 1/4" Flare Nut Branch		No	each	
120	2	LAB18000		A	Label, Danger Warning, .75" x 8" x 006"		No	each	
130	1	LAB18001		A	Label, R134a, 1.25" x 2.5" x 006"		Pr	each	
131	8	ORS20737			O Ring, Seal, 3/8" OD, R-134 #6 Bump		No	each	
140	2	NTM04001			Nut, Hex, 1/4-28unf, 18-8, SS		No	each	
160	18.00	RIV03029			Rivet, Closed End, 3/16" .188-.25, AL/ST		No	each	
170	1	RTB18013		1	Bkt, Dual Filter Drier Receiver, AL		Pr	each	
180	1	RTB18621		0	Bkt, Weldment, Drain Pan		Pr	each	
190	2	RTB18045		0	Bkt, Support, Relay Panel Base, AL		Pr	each	
200	1	RTB18073		1	Bkt, Assem'y, Solenoid, RTC34030		Pr	each	
215	2	STP00500			Switch, HP, Transducer, 0-500, PSIG		No	each	
220	2	SWF18685			Thermostat, Freeze Out, 18" Non-Adj		Ma	each	
230	2	SWP36029			Switch, HP, Open 350-370/CL 270-300 PSIG		No	each	
241	1	SBU00018			Trim, 5/8" bulb x 9/16" x 1/8" x 18"L		Ma	each	
270	2	TUC18600		1	Tube, Sol to TXV, .375" O.D		No	each	
280	1	TUC18040		2	Ass'y, Drier to Sol., .375" OD.		No	each	

Bill of Materials Listing

TransArctic Canada Inc.

Product Number		Date	Description		Typ	Uof M	Weight	Yield
Line	Qty	Component Prod#	Rev#	Description	Location	Typ	Unit	
290	1	TUC18050	1	Ass'y, Drier to Sol. W/Take-Off, .37 OD.		Pr	each	
300	1	TUC18060	1	Plug, Take-Off, #8 FOR		Pr	each	
320	2	VAL12007		Valve Assy, Solenoid, 2 x 3/8 MIO, 12V		No	each	
390	4	3-520106-2		Connector, Tab Assy, .250, 16-14 GA, Male		No	each	
400	2	WLS04000		Washer, Lock, 1/4", 18-8, SS		No	each	
410	4	WFS04001		Washer, Flat, 1/4", 18-8, SS		No	each	
420	2	BTS04075		Bolt, Hex, 1/4-20unc, .75", SS		No	each	
430	2	LAB18004	0	Label, ,Solenoid, Recovery & Evacuation,		No	each	

Bill of Materials Listing

TransArctic Canada Inc.

9/15/2025
Page 1 of 1

Product Number	Date	Description		Typ	Uof M	Weight	Yield	
Line	Qty	Component	Prod#	Rev#	Description	Location	Type	Unit
JEP18010	4/24/2018			1	Sub Kit, Electrical Panel, Roof Top		Ma	
5	1	PAC17909			Box, 17 x 9 x 9		Pr	Each
10	1	EDC03010		1.5	Drivers Control, Electronic, 3 Speed		Pr	each
30	1	ETS10720		0	Temperaure Sensor, Electronic 10K, 72"		No	each
40	1	RTB18047		5	Assembly, Relay Panel		Ma	each
80	2	SCP03079			Screw, PH, PD, 8-32 x .75, 18.8, SS		No	each
90	0.2500	LABOR - ASSEMBLY			Assembly/Factory Labor		No	hours