

Bill of Materials Listing

TransArctic Canada Inc.

5/27/2010
Page 1 of 1

Product Number	Description	Date	Weight	Uof M	Yield
Line Component Prod#	Description	Bin Unit	Qty		
KMG82671	Mt Kit, GMC 8.1L LPG, BBCV, 2 TM-21, '08	3/4/2009	32.97		0
10 BEL81969	Belt, 8gr, 1969mm (77.5") (5080775)	each	1		
20 BMG81003	Bkt, Main, 8.1L GM, 2008, ALUM	each	1		
30 PUL80076	Pulley, Idler, Backside, P8, 76d (89062)	each	2		
40 PUL81003	Pulley, Crank, Add-on, GM, 8.1L, P8	each	1		
45 BMG81004	Bkt, CAC, Sup, 8.1L GM, 2008	each	1		
50 PUL81074	Pulley, Idler, Frontside, P8,74d (89103)	each	1		
60 TEN80005	Tenr, HD Spring, BackSide, CCW (89430)	each	1		
65 HOR02000	Hose, Heater, 2" ID, 36" (76200)	each	0.20		
70 KBG82671	Bag Kit, Fasteners, KMG82671/2071/2670	each	1		

Bill of Materials Listing

TransArctic Canada Inc.

5/27/2010
Page 1 of 1

Product Number	Description	Date	Weight	Uof M	Yield
Line Component Prod#	Description	Bin Unit	Qty		
KBG82671	Bag Kit, Fasteners, KMG82671/2071/2670	8/20/2008	1.83		0
10	BTC08030	Bolt, Hex, 8 x 1.25 x 30mm, 10.9, Plt,FT	each	6	
20	BTC08100	Bolt, Hex, 8 x 1.25 x 100mm, 10.9, Plt	each	8	
30	BTC10090	Bolt, Hex, 10 x 1.5 x 90mm, 10.9, Plt	each	1	
40	BTC10130	Bolt, Hex, 10 x 1.5 x 130mm, 10.9, Plt	each	3	
50	BTC10180	Bolt, Hex, 10 x 1.5 x 180mm, 10.9, Plt	each	1	
60	BTS10001	Bolt, Shoulder, 10mm (89064)	each	3	
70	WFA08000	Washer, Flat, 8mm, 8.8, Plt	each	14	
80	WFA10000	Washer, Flat, 10mm, 8.8, Plt	each	5	
90	WLA08000	Washer, Lock, 8mm, 8.8, Plt	each	8	
100	WLA10000	Washer, Lock, 10mm, 8.8, Plt	each	5	

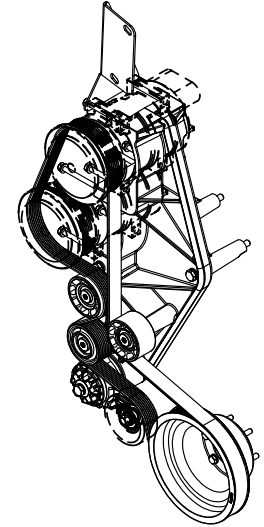
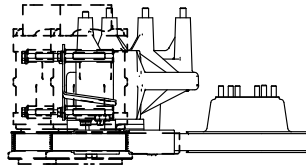

ISOMETRIC VIEW

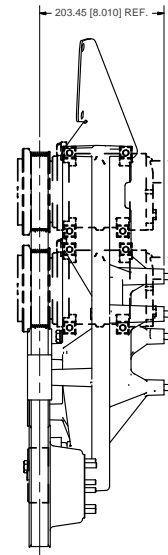
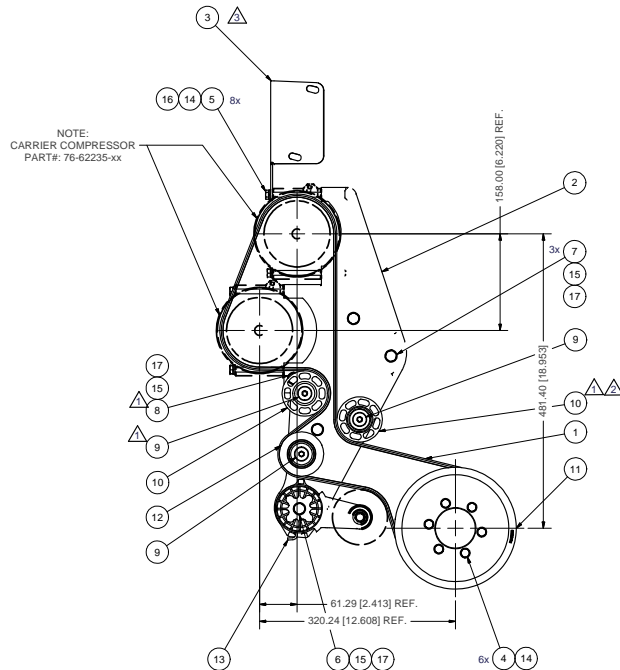

NOTES:

- 1) USE SERVICABLE THREADLOCKER ON ALL FASTENERS TO ENGINE COMPONENTS AND TORQUE ALL BOLTS TO S.A.E. SPECIFICATIONS.
- 2) SEE "TRANSARGTIC A/C COMPRESSOR MOUNT INSTALLATION DISCLAIMER".

ITEM	QTY	U/M	PART NUMBER	DESCRIPTION
17	5	EACH	WLA10000	WASHER, LOCK, 10mm, 8.8, PLT
16	8	EACH	WLA80000	WASHER, LOCK, 8mm, 8.8, PLT
15	5	EACH	WFA10000	WASHER, FLAT, 10mm, 8.8, PLT
14	14	EACH	WFA80000	WASHER, FLAT, 8mm, 8.8, PLT
13	1	EACH	TEN800005	TENR, HD SPRING, BACKSIDE, CCW (89430)
12	1	EACH	PUL81074	PULLEY, IDLER, FRONTSIDE, P8, 74d x 39w
11	1	EACH	PUL81003	PULLEY, CRANK, ADD-ON, GM, 8.1L, P8
10	2	EACH	PUL80076	PULLEY, IDLER, BACKSIDE, P8, 74D, 39W
9	3	EACH	BTS10001	BOLT, SHOULDER, 10mm (IDLER PULLEY)
8	1	EACH	BTC10180	BOLT, HEX, 10 x 1.5 x 180mm, 10.9, PLT
7	3	EACH	BTC10130	BOLT, HEX, 10 x 1.5 x 130mm, 10.9, PLT
6	1	EACH	BTC10090	BOLT, HEX, 10 x 1.5 x 90mm, 10.9, PLT
5	8	EACH	BTC08100	BOLT, HEX, 8 x 1.25 x 100mm, 10.9, PLT
4	6	EACH	BTC08030	BOLT, HEX, 8 x 1.25 x 30mm, 10.9, PLT
3	1	EACH	BMGS1004	BKT, CAC, SUP, 8.1L GM, 2008
2	1	EACH	BMGS1003	BKT, MAIN, 8.1L GM, 2008, ALLUM
1	1	EACH	BEL1969	Belt, 8gr, 1969mm (77.5") (5080775)

BILL OF MATERIALS

3	ADDED BMGS1004	5/27/2010	VAL	DRAWN	Jose Rodriguez	11/19/2008	
2	WAS BEL192018	8/3/2008	JRR	CHECKED	James Stewart	11/19/2008	
1	BEL WAS BEL191812 MISSING	8/8/2008	JRR	DATE	James Stewart	11/19/2008	
0	IDLER PULLEY ADDED/WAS BOLT			RELEASED TO PRODUCTION	11/19/2008	JRR	
REV	DESCRIPTION	DATE	BY	APPROVED			
	THIS DRAWING CONTAINS PROPRIETARY CONFIDENTIAL INFORMATION OWNED BY TRANSARGTIC CANADA INC. THE DOCUMENT AND THE INFORMATION IT IS NOT TO BE USED, DISCLOSED OR REPRODUCED WITHOUT EXPRESS WRITTEN PERMISSION OF THE COMPANY.						
UNSPECIFIED TOLERANCES: H & L DIM (MM)							
ONE DECIMAL PLACE (X1) .1 (10%) (FRACTIONAL)				DRAWING UNIT OF MEASURE: MM (INCH)			
TWO DECIMAL PLACE (X2) .05 (5%) (FRACTIONAL)				SCALE: 1:4			
THREE DECIMAL PLACE (X3) .02 (2%) (FRACTIONAL)				SHEET 1 OF 1			

MT KIT, GMC 8.1L LPG, BBCV, 2 TM-21, '08
 DWG NO: KMG82671
 REV 3



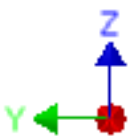
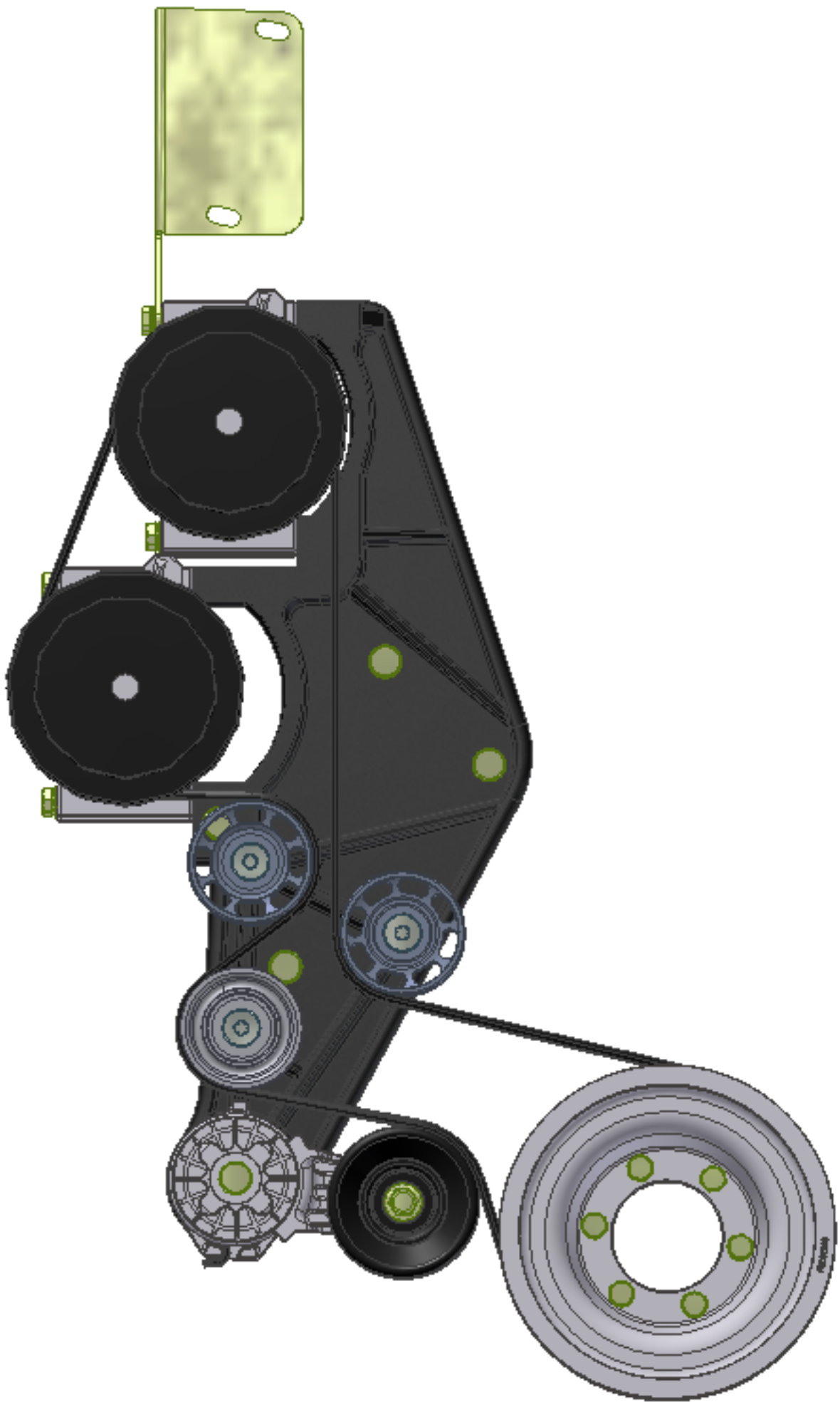

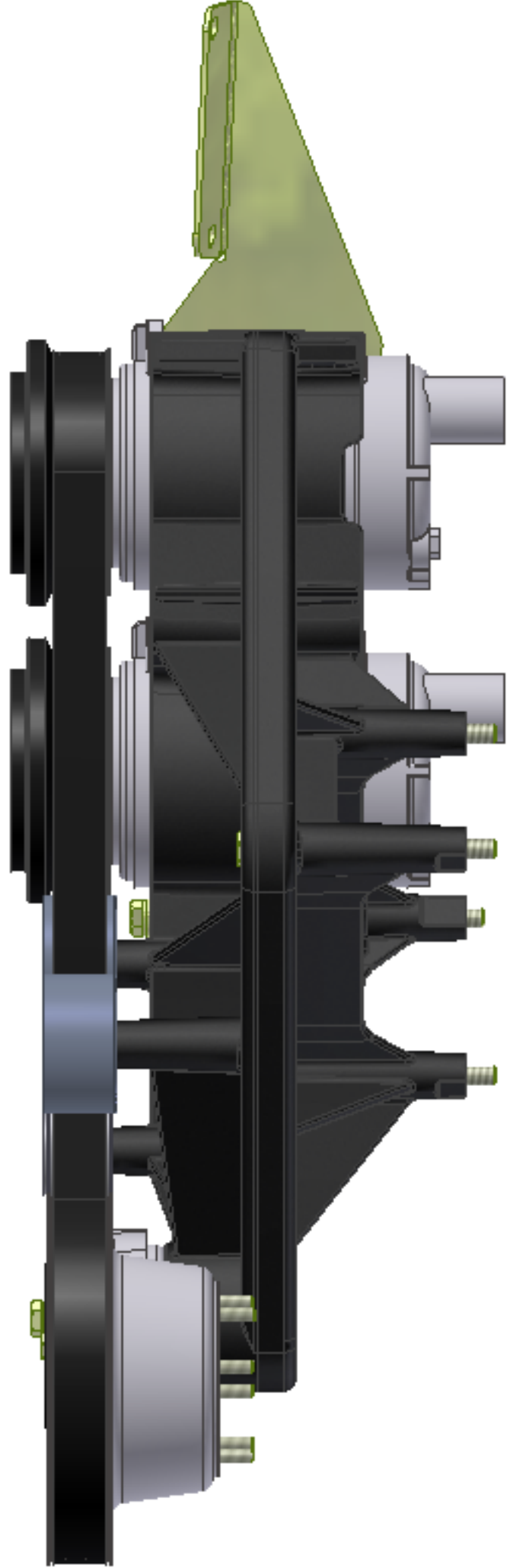

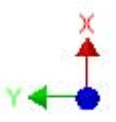
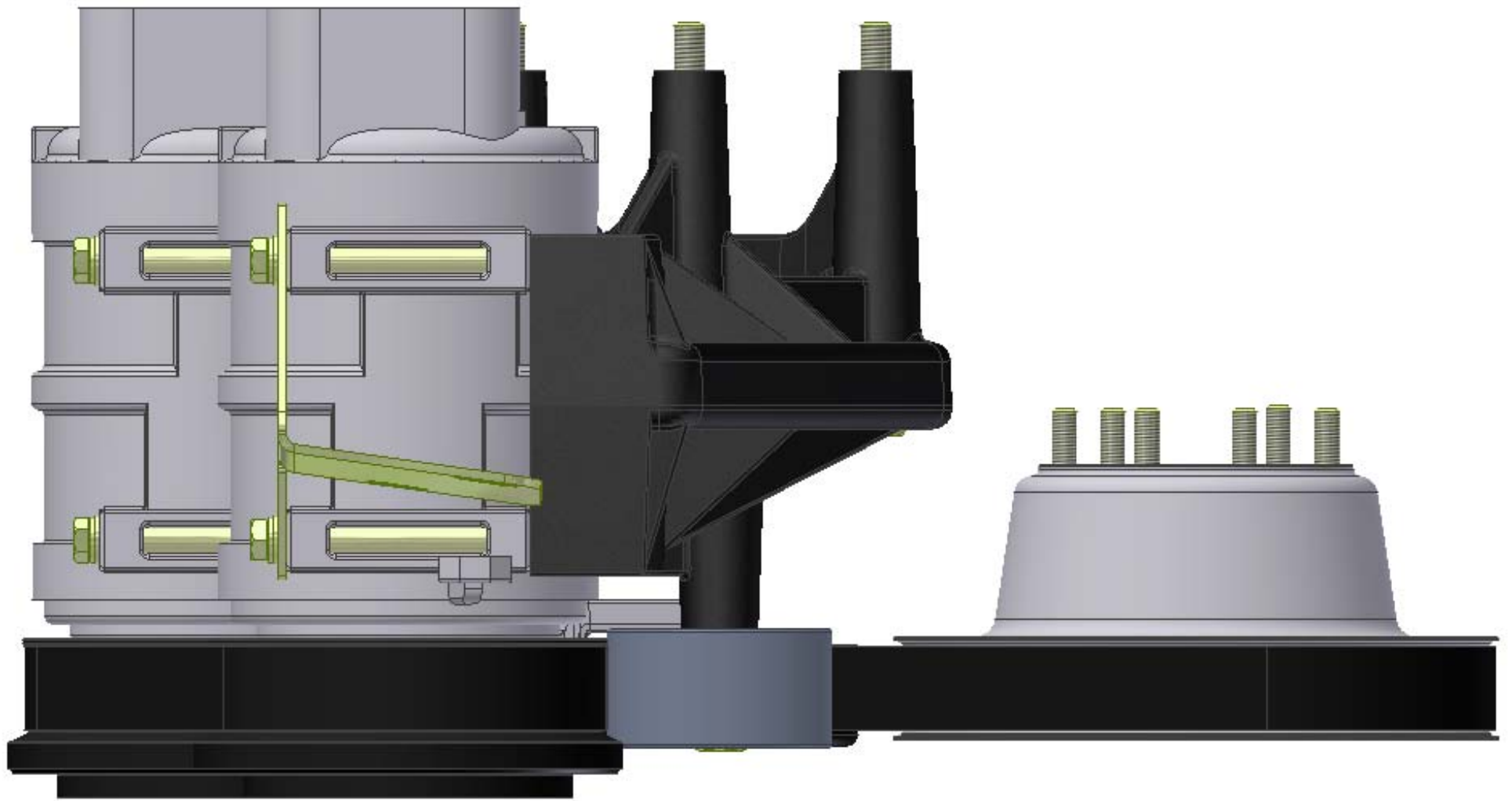

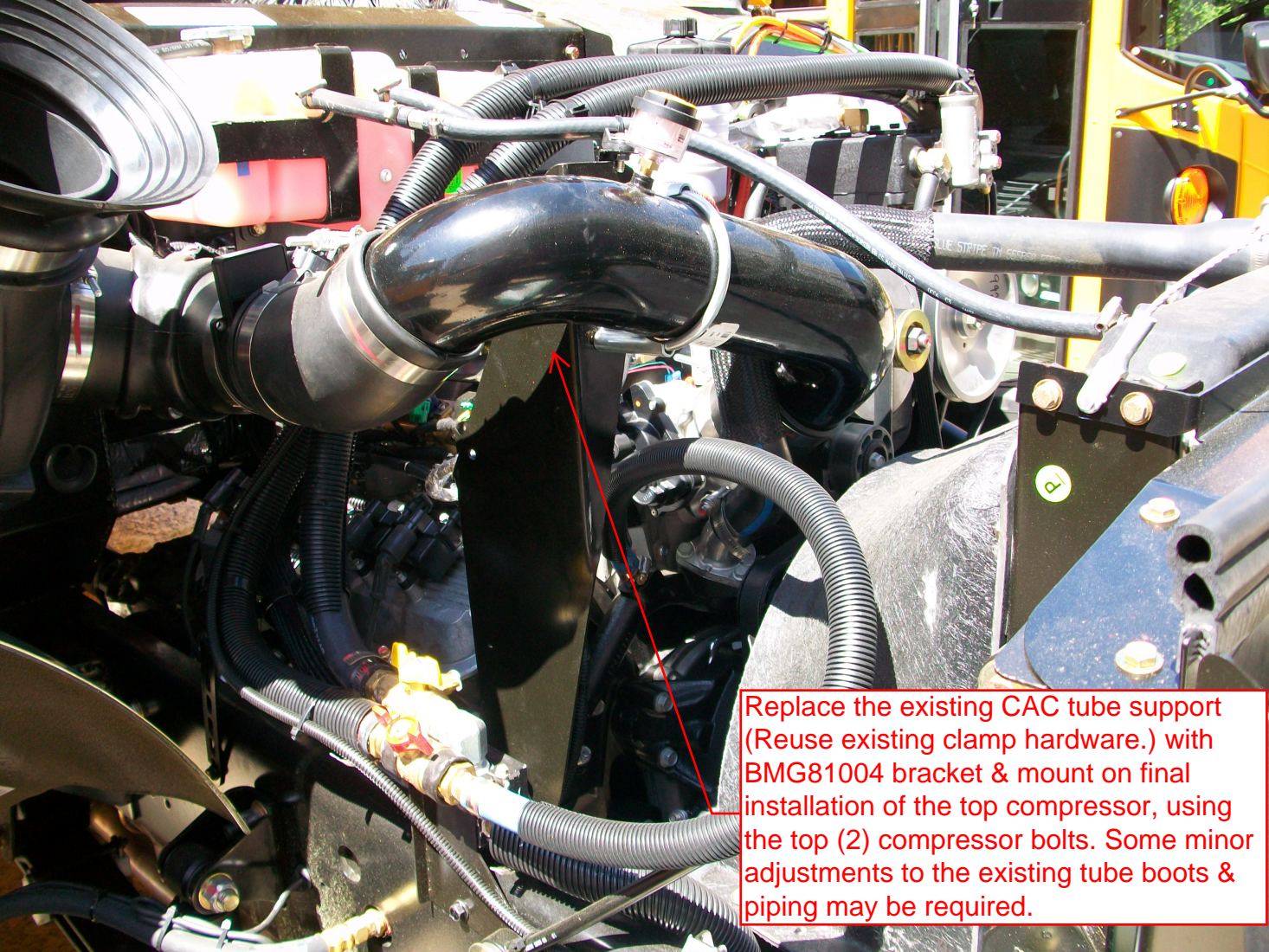

Replace the existing CAC tube support (Reuse existing clamp hardware.) with BMG81004 bracket & mount on final installation of the top compressor, using the top (2) compressor bolts. Some minor adjustments to the existing tube boots & piping may be required.

TransArctic A/C Compressor Mount Installation Disclaimer

All compressor mounts should be installed by qualified and trained personnel using proper tools and equipment in safe working conditions following industry standard guidelines for motor vehicle service and repair.

The installer of any compressor mount purchased from TransArctic must undertake all responsibility of issues arising from that compressor bracket being installed on any vehicle. As well as insure that a **proper and sufficient ground** is established between the compressors' clutches and the vehicle's engine. Mount functionality, operation and durability can all be compromised by an incompetent installation.

Due to the many different situations, parameters and application criteria, which are beyond the compressor mount manufacturer's control, TransArctic does not warrant design, durability, or operational functionality of any compressor mount improperly installed by another party.

With no implied guarantees it is the mount installer's strict responsibility to determine safety and functionality, of the compressor mount, at the time of installation.

Please contact TransArctic with any issue arising from installation so we may better improve the product. If you have any reservations about the compressor mount integrity contact TransArctic immediately at 1-877-COLD-AIR.

Mark OEM tensioner location

Install Kit

Check for Interferences

Check to ensure that the proper OEM tensioner orientation is maintained

Run engine with A/C system engaged for at least 10 minutes to run in belt

Check OEM tensioner orientation and adjust as required

Responsabilidad limitada de TransArctic en la instalación del soporte del compresor

Todos los soportes de los compresores deben ser instalados por personas calificadas y entrenadas, usando para ello los equipos y herramientas necesarios para esta labor en buenas condiciones y según las normas y guías para el servicio y/o reparación de motores de vehículos.

El instalador de los soportes comprados en TransArctic asume toda la responsabilidad de cualquier problema que surga en el soporte del compresor al vehículo; de igual manera es responsable que el cable a tierra sea conectado entre el embrague del compresor y el motor del vehículo.

Se advierte que el buen funcionamiento y la durabilidad del soporte pueden ser comprometidos por defectos en su instalación.

Debido a las diversas situaciones que se puedan presentar fuera del control del fabricante, TransArctic no garantiza el diseño, la durabilidad o el correcto funcionamiento de cualquier equipo inapropiadamente instalado por terceros.

Esta sobreentendido que el Instalador del montaje del compresor es estrictamente responsable de la seguridad y funcionamiento del equipo en el momento de la instalación.

Si tuviera algún problema o duda acerca de la instalación del soporte del compresor pongase en contacto inmediatamente con TransArctic al teléfono 1-877-COLD-AIR de modo que podamos mejorar nuestro producto.

Note la ubicación del medidor de tensión OEM

Instale el equipo

Controlar si hay interferencias.

Asegurese que el medidor de tensión mantenga la orientación justa.

Encienda el motor por lo menos 10 minutos con el sistema A/C enganchado para que la correa corra

Controle la orientación justa del medidor de tensión y ajuste a las condiciones requeridas del fabricante